

RENK

MARINE SOLUTIONS

Double marine gearboxes

Type NDS(H)(Q)(L)

Picture courtesy of ALP Maritime Services

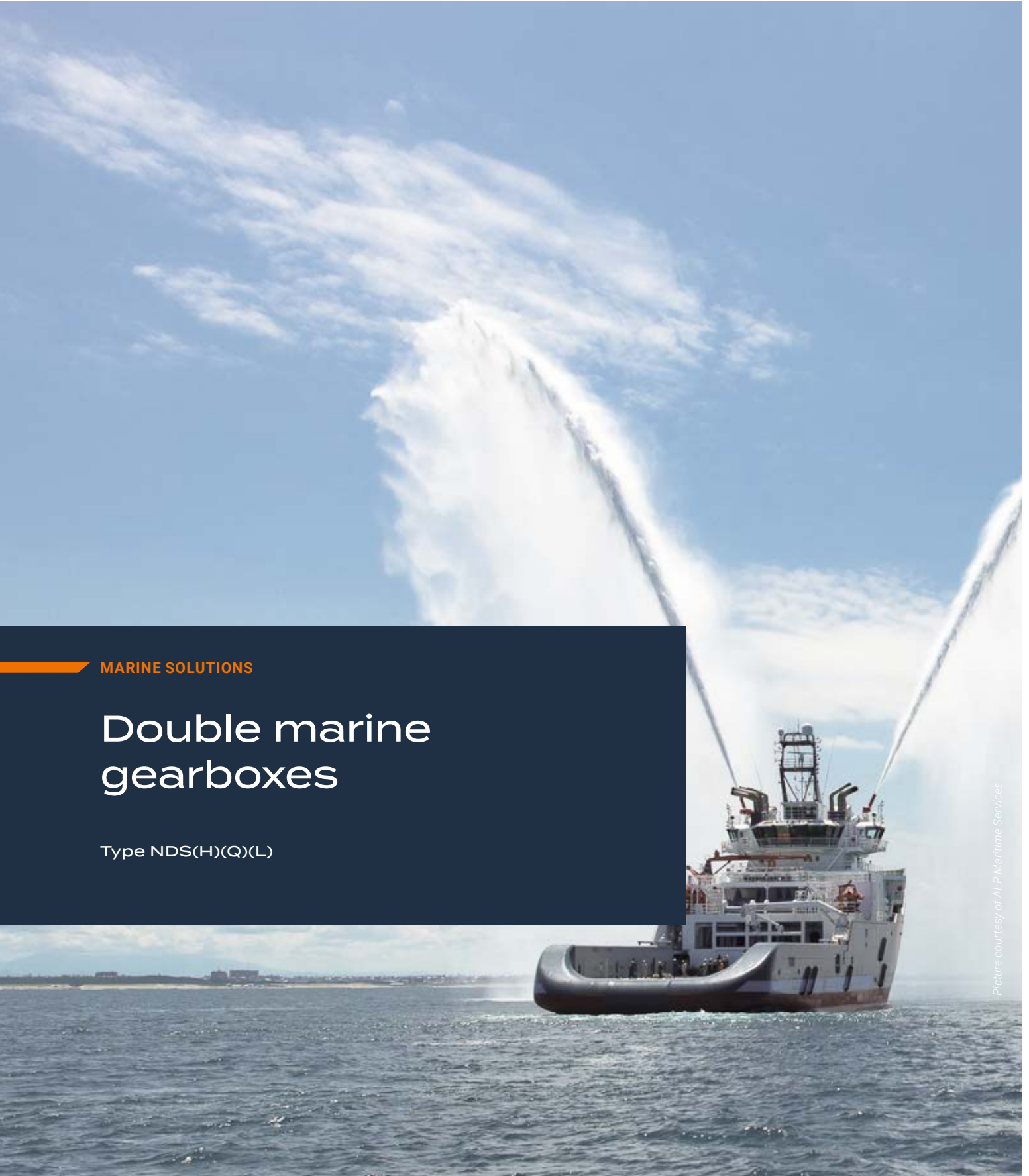

Gear units for the highest demands.



More than 140 years of experience are the basis for the production of highly developed and efficient gear units, which are used in thousands of ships all over the world today. Precisely fitting gear units are our specialty. We develop customized solutions for our customers' demands. RENK gear units extend the performance of double engine marine propulsion by offering a number of additional features. Propeller speed is optimized and power transmission to the main engine is regulated.

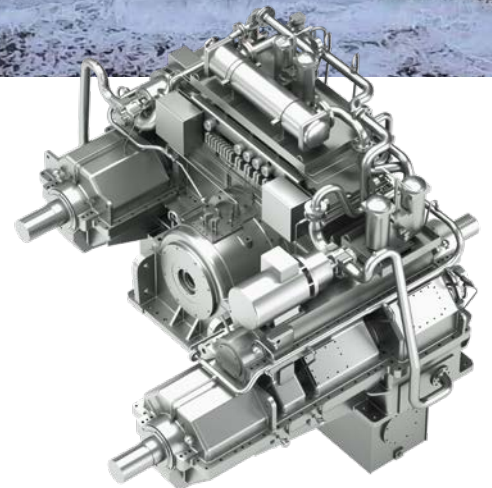

RENK quality standards.



Thanks to the high standards of our internal quality control, RENK offers customers consistent high quality in the development and design of all gear unit components: from gearing technology and axial bearing to the multiple-disc clutch. Precision and diligence in every step of the production as well

as elaborate fine tuning of the separate components comprising the overall system are the key to our quality.

RENK is able to manufacture durable gear units which prove their reliability and high standard of performance for decades and over thousands of miles.

NDS(H)(Q)(L)

- N** = Parallel shafts
- DS** = Double marine gear unit
- H** = Bull wheel, case-hardened
- Q** = Quill shaft design
- L** = Multiple-disc clutch

Hydraulically actuated RENK multiple-disc clutches.

Main propulsion engines as well as auxiliary drives, auxiliary outputs and inputs connected to the gear unit can be engaged or disengaged during operation by means of RENK multiple-disc clutches.

These multiple-disc clutches have been specifically developed by RENK and have proven their high reliability and longevity throughout many years, even under extreme service conditions.

The discs of the hydraulically actuated clutches are made of steel and the outer discs are additionally provided with a profiled inter coating. The discs are forced lubricated and cooled. Clutch engagement/disengagement is hydraulic.

The lube oil and clutch oil circuits are incorporated into the gear unit lubrication and cooling system.

The two-stage engagement system, also developed and optimized by RENK, ensures soft engagement with lowest possible wear.

To avoid increased heating at high power or speeds, the discs are forced-segregated after disengagement.



Offshore

Heavy duty applications such as the offshore market require reliable equipment and flexibility during operation. Outstanding features allow for reliability, versatility and efficiency for the vessel.



Optional equipment.



Turning device

This enables the turning of the propeller shaft on ships with electrical propulsion for safe and comfortable maintenance work.

CPP pump drive

Additional mechanical pump drive at the PTO-shaft for mounting of oil pump to supply oil to the propeller.

Multiple-disc clutch(es)

Can be installed at the main shaft and PTO/PTH/PTI shaft to offer variable drive systems.

Optional holding brakes

For propulsion systems it is possible to lock the propeller for safer and easier maintenance work

Back-to-back test.



Pictures courtesy of Fjord Line



Our RENK plants are equipped with state-of-the-art testing and measuring instruments. Double marine gear units up to the largest sizes can be back-to-back tested under load.

In a back-to-back test configuration, two double marine gear units of mirror-inverted design are connected to each other. With this configuration RENK is able to apply high partial or full load to the gearing by a hydraulic torsion unit.

The closed system is driven by the output shaft or the PTO-shaft. Thus, extensive air and structure-borne noise measurements as well as pressure and temperature measurements can be carried out under load to allow correlations with the operational performance on board. This extensive test is frequently requested by customers and is often the final step within the scope of comprehensive in-house and external quality assurance steps.

Noise reduction.



The quality assurance activities performed throughout the entire production cycle up to the final assembly comply with the requirements set forth by DIN ISO 9001 as well as with specific rules of the classification societies.

The noise and vibration characteristics of the gear units are crucial quality features, particularly on ferries and cruise vessels. RENK has demonstrated for many years that even the highest

requirements can be fulfilled by combining different measures. This can be verified already during the shop test run.

The noise and vibration characteristics are measured by means of a back-to-back test during which the gear units are tested at full load.

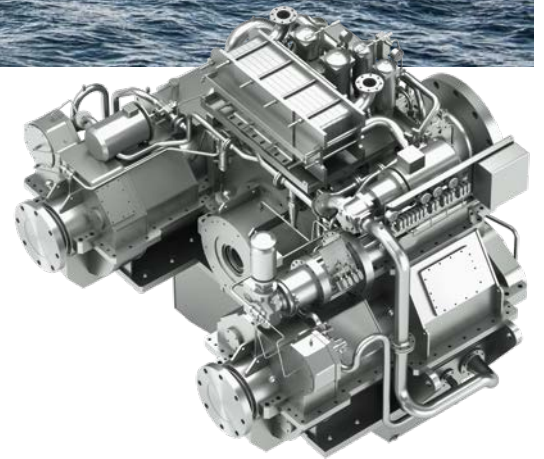

Propulsion system concepts.

Propulsion systems for ships, such as Ro-Pax ferries, supply vessels, ice breakers, etc., are often equipped with

1 or 2 propellers and 2 to 4 engines. The power of two engines each is transmitted to the propeller by a double

marine gear unit. For ships equipped with auxiliary drives "Power Take off", several designs are available.

Drive System PPTO

Primary PTO

Generator operation is possible even if the propeller is at standstill. This means that electricity can still be generated with the main propulsion engine when the ship is not sailing, e.g. in harbors, or additional pumps or auxiliary drives etc. can be driven.

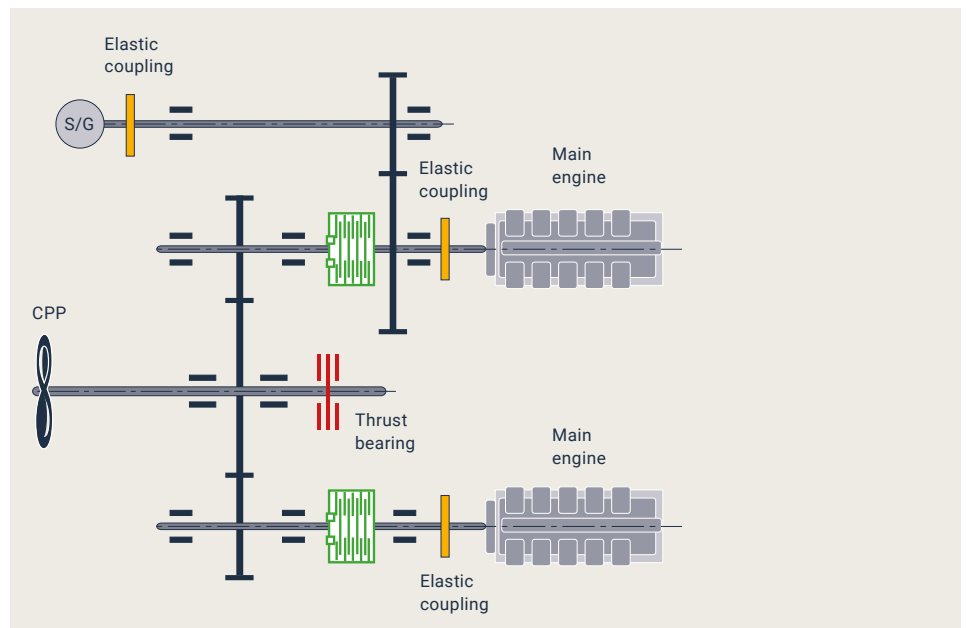

Drive System SPTO

Secondary PTO

Generator operation is possible while the propeller is rotating. Main engine, propeller and generators operating at the same time.

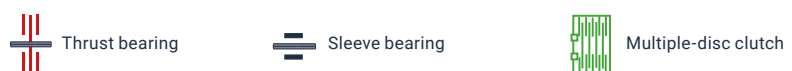
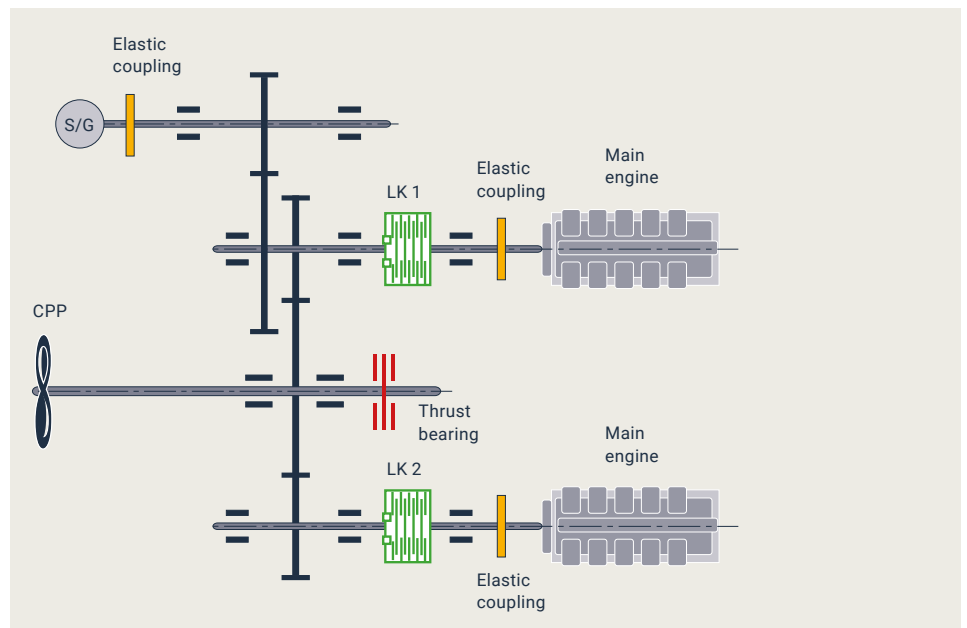

Drive System PPTO/SPTO

PPTO via M/E 1 and SPTO via M/E 2

Combination of both PTO alternatives, offering a primary drive PTO drive, secondary PTO drive with twin screw applications. Combinations of PTOs and screw operation allow for efficient power generation on board. E.g. single screw can be operated while using both PTOs to generate power on board.

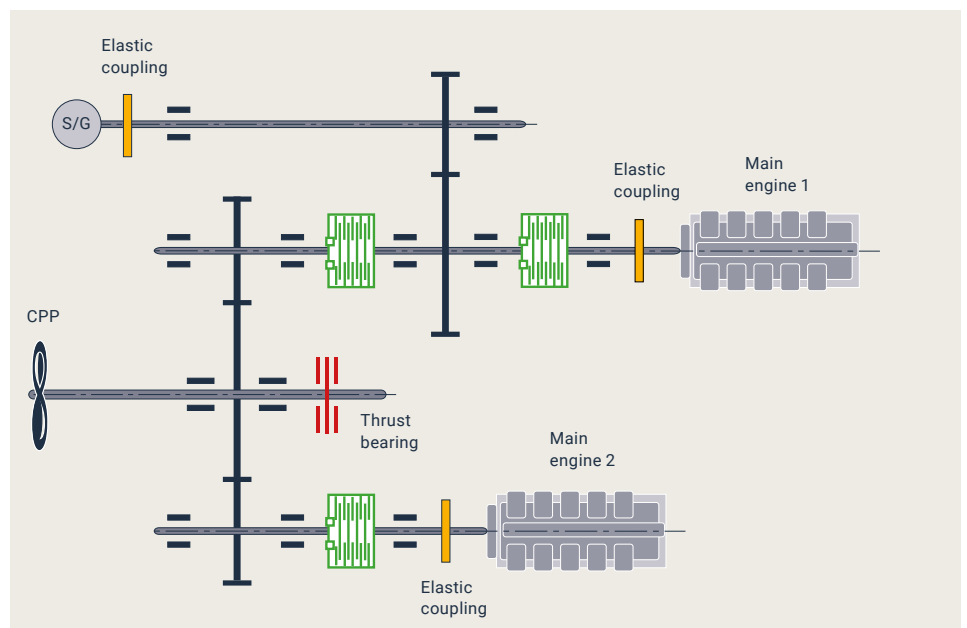

The quill shaft design

Double marine gear units for very high power ranges and equipped with multiple-disc clutches are provided with quill input shafts resulting in the following advantages:

- clear functional separation of the gearing from the input shaft thanks to the hollow shaft design,

- in case of resiliently mounted engines the gear teeth are not adversely affected by misalignments,
- the specific bearing arrangement ensures optimum distribution of the forces.

Widely varying quill shaft combinations can be realized with RENK multiple-disc clutches for tailor-made PTO/PTH and PI configurations.

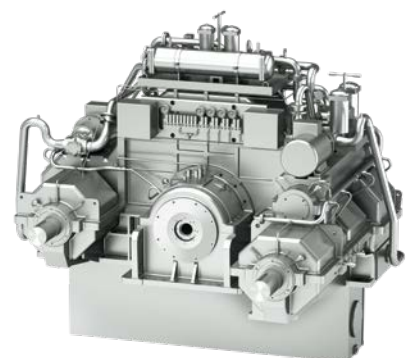

Reliability through precision.

Gearing

The dimensioning and design always focus on the highest safety and lowest noise and vibrations. These objectives are achieved by virtue of the optimum fine tuning of macro and micro gearing geometry.

Bearings

High-quality gear units require bearings with particular properties. RENK cares very much about the selection of safe and amply dimensioned bearings that secure high performance and a long service life.

Thick-walled radial and axial bearings with circular thrust pads provide a trouble-free and durable operation.

The following aspects are of particular advantage:

- Maintenance of the thrust bearing is possible without draining the oil and disassembling the gear unit housing.
- Astern and ahead pads of the thrust bearings are of identical construction, a fact that simplifies replacements to a considerable extent.

Casing

The design of the casing and the foundation considerably influences the load-carrying characteristics of the gearing and bearings as well as noise and vibrations. For this reason, the casings are built torsionally stiff with strong internal ribs and are partly manufactured with double walls. As a standard, the thrust bearing is located on the engine side. This arrangement provides high stiffness at the foundation in the thrust bearing area by linking the gear units foundation with the engine foundation for optimum absorption of the propeller thrust forces.



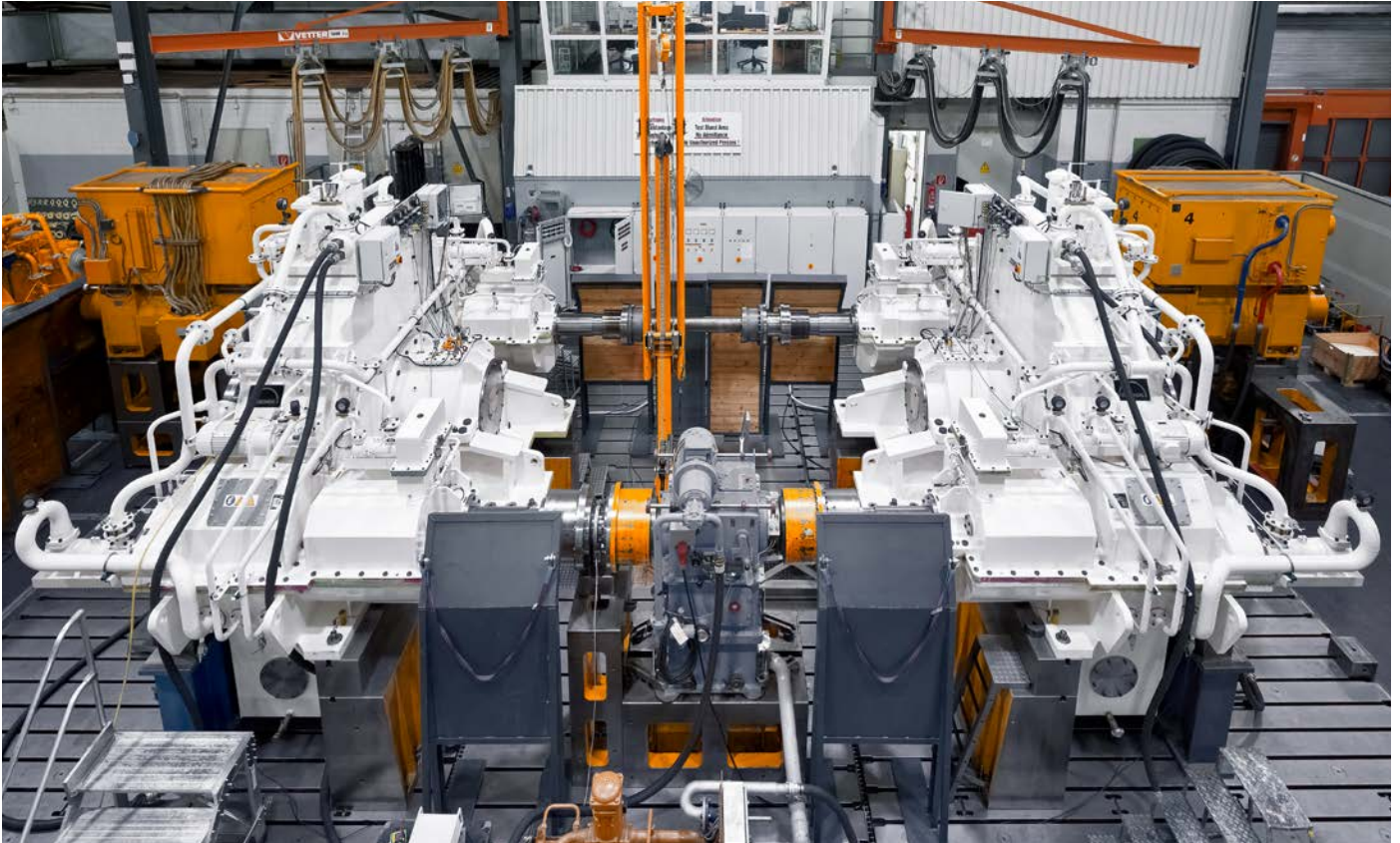

RENK product support – competent, effective and always there for you.

Our customer service is the central contact point for our whole service line-up, be it for general questions about our products and services or maintenance and repair enquiries. A team of experienced engineers and highly qualified personnel supports you in your choice of individual solutions and accompanies the quick execution of the contract – from development to implementation of our gear unit in the propulsion system of your ship. – Even after delivery and professional implementation of the RENK gear unit our team stays a competent partner for all your concerns.

RENK maintenance and repair service – maximized capacity and service life for ship gear units

Our state-of-the-art maintenance and repair equipment ensures first class service:

- 3D gear teeth measurement
- 3D coordinate measuring machine
- Crack testing, surface testing and ultrasonic testing
- Endoscope for internal inspection

Upon completion of the analysis, you will receive a study report containing prevention measures and repair recommendations for all components of the gear unit. We are available 24/7, we answer all of your questions and even at short notice we are able to provide technical personnel to help you complete your tasks quickly and straightforwardly. Our competent team is kept up to date by regular training and is able to answer any new questions that may arise.



Trusted Partner.

RENK GmbH

Rodder Damm 170

48432 Rheine

Germany

P +49 5971 790-0

E info.rheine@renk.com

www.renk.com

Details provided about the properties and usability of the products are purely for information purposes and do not constitute a guarantee of these characteristics. The extent of goods delivered is determined by the subject matter of the specific contract. No liability accepted for errors or omissions. Subject to technical alterations. © RENK 2023