

## ASSEMBLY AND OPERATING INSTRUCTIONS

# ELCO coupling: Type N | W | KWU

Issue date: 2024-05 | Version: V01 | English

**Target group: Service technicians, trained specialists**

## Contact

RENK GmbH | Weltausstellungsallee 21  
30539 Hanover | Germany  
Phone: +49 511 8601-0  
E-mail: [elco\\_couplings@renk.com](mailto:elco_couplings@renk.com) | Web: [www.renk.com](http://www.renk.com)

## Document version

Document number: RH-BA-ELCO-N-W-KWU\_ENG\_V01

Version	Issue date	Change
01	2024-05	Creation

© 2024 RENK GmbH  
Passing on or copying this document, using and providing information on its contents is prohibited unless expressly permitted. Contraventions will be subject to compensation. All rights reserved in the matter of patent, utility model or design registration.

## Table of contents

Contact.....	2
Document version .....	2
Table of contents .....	3
1 Information regarding the operating instructions .....	5
1.1 Applicable documents .....	5
1.2 Presentation conventions .....	6
2 Safety.....	7
2.1 Intended use.....	7
2.2 Responsibility of the operator .....	8
2.3 Personnel qualifications .....	8
2.4 Personal protective equipment.....	9
2.5 Safety instructions for the individual operating phases .....	10
2.5.1 Transport and storage.....	10
2.5.2 Assembly and installation .....	10
2.5.3 Commissioning and operation .....	11
2.5.4 Maintenance.....	11
2.5.5 Disassembly and disposal .....	12
2.6 Safety at work.....	12
3 Description of the ELCO coupling .....	13
3.1 Technical information .....	13
3.1.1 Type N: Size 018-129 .....	14
3.1.2 Type N: Size 149-454 .....	15
3.1.3 Type W.....	16
3.1.4 Type KWU.....	17
3.2 Type designation of the ELCO coupling.....	18
3.3 Technical data .....	19
3.3.1 Technical data and dimensions .....	19
3.3.2 Weights .....	23
4 Transport and storage .....	24
4.1 Condition of delivery .....	24
4.2 Transport .....	25
4.3 Storage .....	26
4.4 Corrosion protection .....	26
4.4.1 Delivery condition.....	27
4.4.2 Inspection.....	28
4.4.3 Post-preservation .....	29
4.4.4 Removal .....	30
4.5 Additional corrosion protection .....	31
5 Assembly .....	32
5.1 Warnings .....	32
5.2 Preparations .....	33
5.3 Markings on the coupling .....	34
5.3.1 Coupling sleeves.....	34
5.3.2 Optional wear indicator .....	34
5.4 Preparing the coupling for installation .....	35
5.5 Installing the coupling.....	35
5.5.1 Tapered bore.....	35
5.5.2 Cylindrical bore .....	36
5.6 Align shafts .....	37

---

5.7	Permitted displacements .....	38
5.8	Mounting transmission elements.....	40
5.8.1	Type N: Size 018-129 .....	40
5.8.2	Type N: Size 149-454 .....	41
5.8.3	Type W.....	43
5.8.4	Type KWU .....	45
6	Malfunctions.....	47
6.1	Warnings .....	47
6.2	Troubleshooting.....	48
6.3	Spare parts .....	48
7	Maintenance .....	49
7.1	Warnings .....	49
7.2	Maintenance schedule .....	51
7.3	Replacing the coupling sleeves.....	52
7.3.1	Type N: Size 018-129 .....	52
7.3.2	Type N: Size 149-454 .....	53
7.3.3	Type W.....	54
7.3.4	Type KWU .....	55
7.4	Cleaning .....	56
8	Disposal .....	57
8.1	Disposal of operating materials .....	57
8.2	Disposal of components .....	57
9	Annex.....	58
9.1	Appendix A   Other applicable documents .....	58
9.2	Annex B   Safety data sheets .....	58
9.3	Annex C   ATEX   OPTIONAL* .....	58

# 1 Information regarding the operating instructions

These operating instructions describe the transport, assembly, operation, maintenance, disassembly and disposal of the ELCO coupling. Use this operating manual only for the specified ELCO coupling.

- ▶ Read this operating manual completely; in particular → chapter 2, page 7, before working with the ELCO coupling.
- ▶ Observe all generally applicable, legal and other binding regulations in European or national legislation as well as the regulations that apply in your country for accident prevention, handling hazardous substances and environmental protection.

The operating instructions form an integral part of the ELCO coupling and must be kept in the immediate vicinity of the ELCO coupling, accessible to personnel at all times, complete and in a legible condition.

Personnel must have carefully read and fully understood this operating manual before the start of any work. Adherence to all the safety and operating instructions stated in these operating instructions is the basic prerequisite for safe working.

## 1.1 Applicable documents

In order to use the ELCO coupling safely and correctly, observe the applicable documents, such as drawings, technical documents, safety data sheets, operating instructions and catalogues.

Type KWU

The ELCO coupling of the **KWU type** is specified for use in potentially explosive atmospheres. In addition to these operating instructions, supplementary operating instructions (Ex003) for the use of ELCO couplings in potentially explosive atmospheres can be supplied as an option. You must observe the information and regulations in these supplementary operating instructions (Ex003).



- ▶ Always have the complete documentation ready and available for all work.
- ▶ If the operator changes, the complete documentation must be passed on to the successor.
- ▶ The illustrations shown may differ from the final product. In the event of contradictory illustrations and data, always observe the illustrations and data in the dimensions sheet.
- ▶ If information is missing or unclear, please contact the Service Department → Contact, page 2, before starting work.

## 1.2 Presentation conventions



Warnings refer to entire chapters or sections, subsections or several paragraphs within these operating instructions. Warnings are structured as follows:

 <b>SIGNAL WORD</b>	<b>Type and source of the hazard!</b> Consequences of non-compliance. ▶ Measures to avoid the hazard.
--	---

Classification of warnings

Signal word panel	Type of hazard
 <b>DANGER</b>	Warns of imminent hazard leading to death or serious injury if not avoided.
 <b>WARNING</b>	Warns of a potentially hazardous situation leading to death or serious injury if not avoided.
 <b>CAUTION</b>	Warns of a potentially hazardous situation leading to moderate or minor injury if not avoided.
<b>NOTICE</b>	Warns of a potentially hazardous situation leading to material damage if not avoided.

Symbols and markings

Marking	Description
▶	The arrow indicates an instruction.
[ ]	The number in square brackets refers to a specific part of the bearing that is indicated in the drawings and in the parts lists.
→ chapter 1, page 5	Cross-references that refer to a different section in the document are preceded by an arrow. When you click on the corresponding text, you will automatically jump to the corresponding place in the document.
	Notes, tips and recommendations for alternative use or special knowledge are indicated with this symbol.
	Notes on environmental protection indicate a potentially harmful situation for the environment as a result of operation, maintenance or repair.

## 2 Safety

This chapter summarises the essential safety instructions that apply to the ELCO coupling. This chapter must be read and understood by all persons who come into contact with the ELCO coupling. Special safety instructions and warnings may be necessary for individual tasks. You will only find these special safety instructions in the description of this work.

The following safety instructions must be understood as a supplement to the already applicable national accident prevention regulations and laws. You must comply with existing accident prevention regulations and laws in any case.

- Principle
- ▶ Operate the ELCO coupling only if it is in technically perfect condition and in accordance with the intended purpose, safety and hazard-consciously, and in compliance with these operating instructions.
  - ▶ Immediately rectify any faults that may affect the safety of persons.
  - ▶ Make sure that no safety devices are dismantled, put out of operation or changed.
  - ▶ Make sure that safety devices that have been removed for maintenance work are reassembled immediately after completion of the work.
  - ▶ Check the operational safety before each commissioning. If defects or malfunctions are established, they must be rectified immediately.
  - ▶ If defects or faults are established during operation, you must cease operation immediately. Rectify the defect or fault before starting.

### 2.1 Intended use

The ELCO coupling is intended for use in drive systems to create a torsionally flexible connection of shafts. The ELCO coupling is intended for installation in a machine or for assembly with other machines to form a complete machine or complete unit.

Coupling sleeves V

If the ELCO coupling is used as intended, the SVHC substance (imidazolidine-2-thione, CAS No. 96-45-7) contained in the **coupling sleeves V** does not pose a risk → chapter 8, page 57.

- Always use the ELCO coupling in accordance with its intended use, taking into account the permissible loads, operating conditions and specifications in the technical data.
- Follow the operating instructions and the applicable documents.
- Only use original RENK spare parts or approved spare parts.
- Only carry out any conversions or additions with accessories after written approval by RENK.

- Improper use
- In the event of improper use, there is a risk of personal injury, material damage and failure of the ELCO coupling, for which the manufacturer shall not be liable. The following improper uses are prohibited:
- Use of the ELCO coupling outside the specifications stated in the technical data.
  - Operation of the ELCO coupling without using suitable protective devices.
  - Unauthorised modifications or changes to the ELCO coupling.
  - If welding is carried out in the vicinity of the ELCO coupling, the ELCO coupling may not be located between the weld seam and the earthing of the welding system. The ELCO coupling must not be in the circuit.

## 2.2 Responsibility of the operator

Only trained and qualified specialist personnel who have read and understood the operating instructions may be commissioned by the operator to work on the ELCO coupling.

The operator is responsible for proper transport, assembly, operation, maintenance and servicing, as well as disposal.

The operator may not perform any changes, extensions or conversions to the ELCO coupling without the consent of RENK. This also applies to assembly procedures, settings for safety devices and welding work on parts of the ELCO coupling.

The operator must ensure that systems into which the ELCO coupling has been installed are equipped with additional monitoring and protection devices. The safety regulations and laws that apply for technical work equipment and accident prevention regulations must be observed.

## 2.3 Personnel qualifications

These operating instructions are intended exclusively for authorised, trained and qualified specialist personnel with specific knowledge of mechanical, hydraulic and electrical work. All work on the ELCO coupling requires both mechanical and electrical knowledge.

Specialist in mechanical work

All mechanical and hydraulic work may only be carried out by a trained specialist. With their professional training, knowledge and experience as well as knowledge of the relevant standards and regulations, specialists in mechanical work are able to carry out mechanical and hydraulic work and independently identify and avoid possible hazards.

Specialist in electrical engineering work







All electrical work may only be carried out by a trained specialist. With their professional training, knowledge and experience as well as knowledge of the relevant standards and regulations, qualified electricians are able to carry out work on electrical systems and independently identify and avoid possible hazards.

- ▶ The operator must instruct the specialist personnel in the safe and proper use of the ELCO coupling.
- ▶ Every person who works with the ELCO coupling must have read and understood this operating manual.

## 2.4 Personal protective equipment

The purpose of personal protective equipment is protecting persons from hazards to safety and health at work. The operator must provide the personnel with sufficient protective equipment. Safety helmets, safety gloves and safety shoes are mandatory for all persons working on or with the ELCO coupling.

- ▶ When handling lubricating oil, preservatives, solvents, cleaning agents and hydraulic fluid, the protective equipment prescribed in the relevant product and safety data sheets must be worn.

Mandatory signs	Meaning	Description
	Wear safety shoes	Safety shoes offer proper slip resistance, particularly in wet conditions, as well as a high degree of surefootedness.
	Wear a safety helmet	Safety helmets protect against head injuries, falling objects or impacts, particularly in the event of low ceiling heights and overhead mounting.
	Wear safety gloves	Safety gloves protect the hands from minor crushing, cutting injuries, infections and hot surfaces, particularly during unpacking, commissioning, maintenance, repair and disassembly.
	Wear hearing protection	Hearing protection protects the hearing from excessively loud noises and prevents acoustic trauma, particularly in the vicinity of machines.
	Wear protective clothing	Protective clothing protects the skin from light mechanical impacts and in the event of leakage of liquids.
	Wear safety goggles	Safety goggles protect the eyes in the event of leakage of liquids, particularly during commissioning, maintenance, repair and decommissioning.

## 2.5 Safety instructions for the individual operating phases

- Observe all generally applicable national regulations for accident prevention, handling of hazardous substances and environmental protection.
- Regularly check the ELCO coupling for obvious defects.
- Only appropriately trained, instructed and authorised specialist personnel may assemble, install and operate the ELCO coupling.
- Operate the ELCO coupling only within the power range that is specified in the technical data.
- If you temporarily remove or decommission safety devices, for example, for commissioning or maintenance work, you must make sure that no dangerous situations can arise for people and property.
- Make sure that all safety devices are reinstalled or put back into operation after completion of the work.
- Make sure that there is adequate lighting when working on the ELCO coupling.
- Make sure that all first aid and fire-fighting equipment is always in perfect condition and good working order.
- When handling hazardous substances, make sure that the latest safety data sheets from the hazardous substance manufacturers are available. The necessary measures can be found in the contents of the safety data sheet. Since the hazard potential of a substance may be reassessed at any time based on new findings, the safety data sheet must be regularly reviewed and replaced if necessary.

### 2.5.1 Transport and storage

- Only trained and authorised specialist personnel may prepare and load the ELCO coupling for transport.
- Lifting equipment with insufficient load-bearing capacity may bend and endanger people or damage objects. For loading, use only lifting equipment that is able to support the weight of the ELCO coupling and its components.
- Lifting ropes and slings with insufficient load-bearing capacity may break when lifting the ELCO coupling and its components, which may cause the ELCO coupling or its components to fall, endangering persons or damaging objects. Only use ropes and slings with sufficient load-bearing capacity.
- If eyebolts are used, they must be firmly tightened. Always check that the eyebolts are firmly tightened before moving or lifting the ELCO coupling. Loosened eyebolts may come loose and the components may come loose and fall, which may result in injury.
- Make sure that the eyebolts are only subjected to tension and not to bending. The eyebolts may break if under a bending load and the loosened parts may fall and cause injury.
- Incorrectly fastened ropes may damage the ELCO coupling or its components during transport. Attach the ropes only to the designated lifting points.
- Before moving the ELCO coupling or its components with eye bolts, make sure that the bolts are firmly tightened on the part grooves, otherwise the parts may become loose.

### 2.5.2 Assembly and installation

- Only carry out work on the ELCO coupling while it is not in operation. Make sure that the system is secured against unintentional restarting.
- Make sure that the working environment is perfectly clean. Cover the opened ELCO coupling during any work breaks.
- Make sure that the safety devices are always freely accessible.

### 2.5.3 Commissioning and operation

- Only put the ELCO coupling into operation if it is fully assembled, with all safety devices installed and in working order.
- Before commissioning, check the proper condition of the ELCO coupling. Report any faults, damage or changes to the operator immediately.
- Malfunctions on the ELCO coupling must be rectified immediately.
- If changes in operating behaviour or malfunctions occur during use of the ELCO coupling, the ELCO coupling must be taken out of operation immediately and the causes eliminated.

### 2.5.4 Maintenance

- During maintenance and repair work, you must partially deactivate or remove protective devices. Replace the protective devices immediately after completion of maintenance and repair work and make sure that they are functioning properly.
- Wait until the ELCO coupling and the adjacent machine parts have come to a standstill before removing the protective devices. Please note that the ELCO coupling may continue to run for a longer period of time.
- Allow the ELCO coupling and the adjacent machine parts to cool down sufficiently before starting work, to avoid burns.
- Only carry out work on the ELCO coupling while it is not in operation. Make sure that the system is secured against unintentional restarting.
- Make sure that the working environment is perfectly clean. Cover the opened ELCO coupling during any work breaks.
- Reassemble the disassembled safety guards and check their function before operating the ELCO coupling.
- Unsuitable equipment may damage the ELCO coupling and its parts. Use only specified equipment → chapter 3.3, page 19. Do not use equipment whose characteristics you are unfamiliar with. If in doubt, please contact the manufacturer of the material or equipment.
- Never mix equipment of different types and from different manufacturers. Only use a container that is approved for the respective equipment and label it accordingly.
- When handling lubricants, preservatives, solvents, cleaning agents and hydraulic fluids, the protective equipment prescribed in the relevant product and safety data sheets must be worn.

### 2.5.5 Disassembly and disposal

- Allow the ELCO coupling and the adjacent machine parts to cool down sufficiently before starting work, to avoid burns.
- When handling oil, make sure that no oil leaks into the ground or into the sewer system. Used oil, used greases and cleaning rags contaminated with oil or grease must be disposed of in an environmentally friendly manner in accordance with the national regulations of your country and in accordance with the applicable safety data sheets. Organic oils and mineral oils must be disposed of separately.
- Dispose of the operating materials and components of the ELCO coupling in accordance with the national regulations that apply in your country.

## 2.6 Safety at work

- ▶ Wear the protective equipment as prescribed in → chapter 2.4, page 9.
- ▶ Wear the protective equipment as prescribed in the safety data sheets of the respective equipment.
- ▶ When handling flammable equipment, observe the product data sheets and safety data sheets of the respective manufacturer.
- ▶ Do not wear loose clothing, jewellery or loose long hair.
- ▶ Change your clothes immediately if they have been soiled with highly flammable substances.
- ▶ Do not eat, drink and smoke during work.
- ▶ Keep away from fire and naked flames when working on the ELCO coupling and when handling flammable equipment.
- ▶ Do not smoke in the vicinity of flammable equipment.

## 3 Description of the ELCO coupling

### 3.1 Technical information

The installation of a correctly designed ELCO coupling reduces torque and speed surges and protects systems from damage and consequential costs. Thanks to the special spring and damping properties of the profiled coupling sleeves, torsional vibrations are effectively limited.

The special design of the ELCO coupling ensures fail-safe and coherent torque transmission. It allows limited radial and angular displacements of the shafts to be connected and absorbs limited axial displacements.

The coupling flanges of the adaptable ELCO coupling are made of steel or a special material. The standard design has transmission elements arranged on one side or both sides, but special designs are also possible here.

Coupling sleeves	<p>All designs of the ELCO coupling can be equipped with any of these coupling sleeves.</p> <p>Coupling sleeves <b>U</b> (modified natural rubber) with polyamide inner sleeves vulcanised into the bores are used for all regular drives and have also proven themselves for use with non-uniformly operating drives with alternating torques, in particular for machines that are subject to vibration, e.g. diesel engines and other piston engines.</p> <p>Coupling sleeves <b>V</b> (chloroprene polymer) with polyamide inner sleeves vulcanised into the bores are used in particular for couplings that are exposed to oil vapours (mineral oils). These can also be used for systems in tropical areas with a risk of termites.</p> <p>Coupling sleeves <b>W</b> (nitrile rubber) with polyamide inner sleeves are used for drives that require smaller angles of rotation than can be achieved with U. W-sleeves are oil-resistant, subject to conditions.</p>
Properties	<ul style="list-style-type: none"><li>• Particularly good torsion spring and damping properties</li><li>• Reduction of torque and speed surges</li><li>• Reduction of torsional vibrations</li><li>• fail-safe and coherent torque transmission</li><li>• Compensation of radial and angular displacements</li><li>• Compensation of axial displacements</li><li>• Trouble-free axial removal of the coupling sleeves and bolts</li></ul>

3.1.1 Type N: Size 018-129

The **Type N: Size 018-129** describes the design of transmission elements arranged on one side. The transmission elements consist of the bolt [4], on each of which a coupling sleeve [5] is secured by a grooved pin [7] and a washer [9]. The transmission elements are located between the two coupling halves [1] and [2].

Variant 1

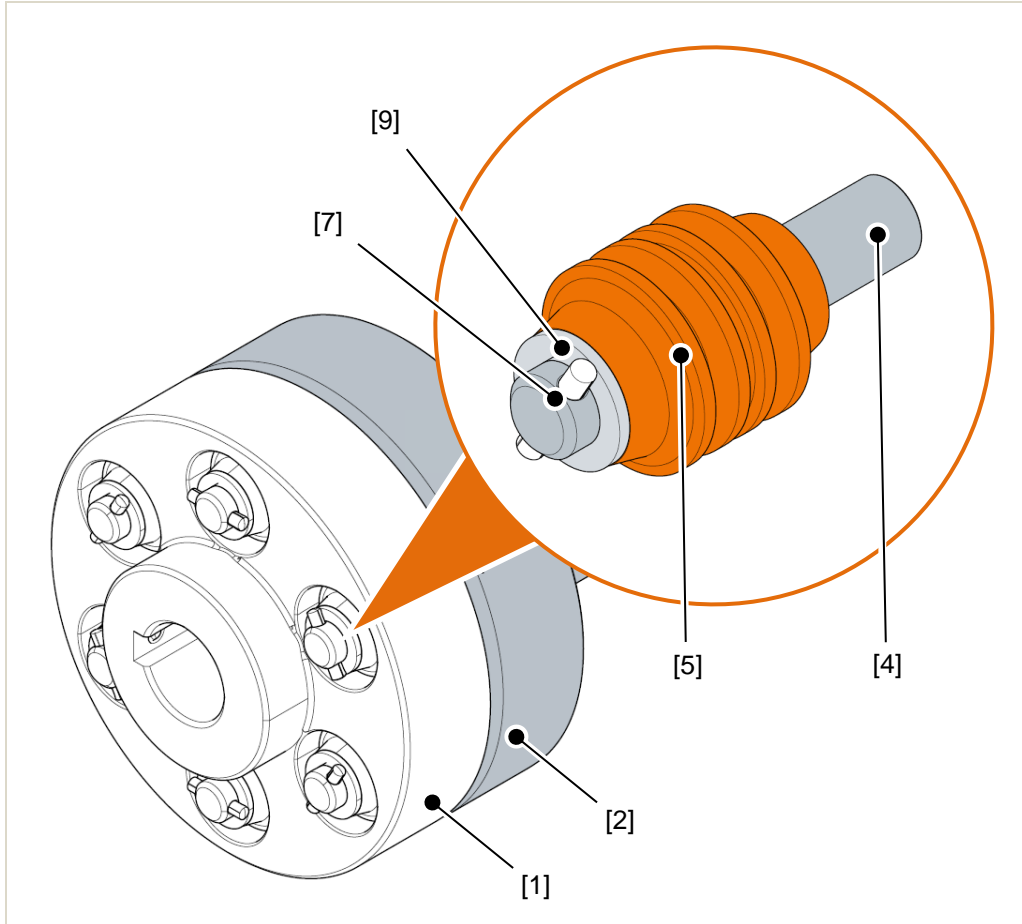

**Abb. 1 Type N: Size 018-129**

- |                   |                     |
|-------------------|---------------------|
| [1] Coupling half | [5] Coupling sleeve |
| [2] Coupling half | [7] Grooved pin     |
| [4] Bolt          | [9] Disc            |

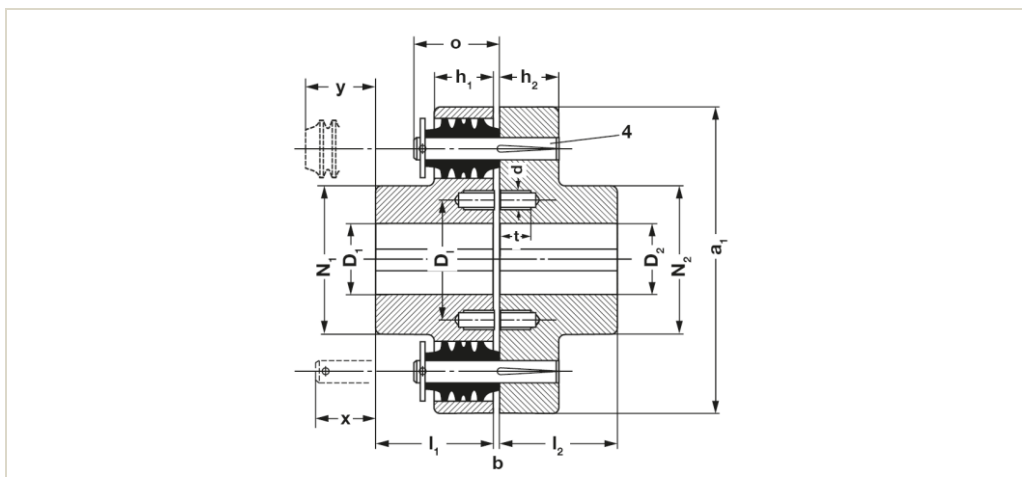

### 3.1.2 Type N: Size 149-454

The **Type N: Size 149-454** describes the design of transmission elements arranged on one side. The transmission elements consist of the bolt [6], on each of which a coupling sleeve [5] is secured by a disc [9] and a retaining ring [10].

The design of the bolt in solid or hollow drilled design depends on the speed of the ELCO coupling used. The transmission elements are located between the two coupling halves [1] and [2] and are fastened by a hexagon nut [8].

Variant 2

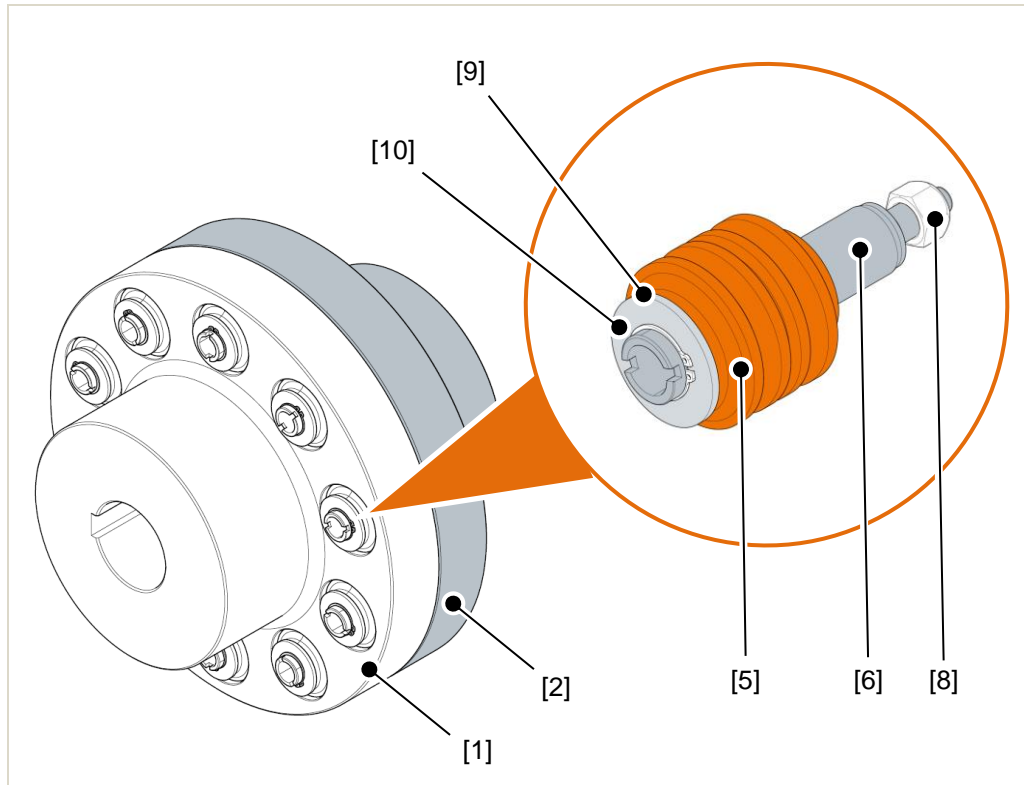

**Abb. 2 Type N: Size 149-454**

- |                     |                     |
|---------------------|---------------------|
| [1] Coupling half   | [8] Hexagon nut     |
| [2] Coupling half   | [9] Disc            |
| [5] Coupling sleeve | [10] Retaining ring |
| [6] Bolt            |                     |

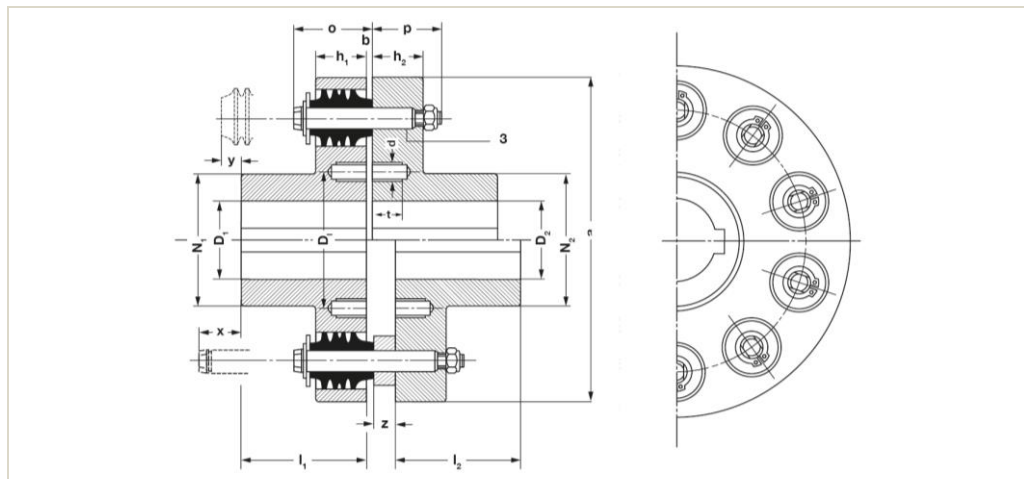

### 3.1.3 Type W

The **W design** describes the design of alternately arranged transmission elements. The transmission elements consist of the bolt [6], on each of which a coupling sleeve [5] is secured by a disc [9] and a retaining ring [10].

The design of the bolt in solid or hollow drilled design depends on the speed of the ELCO coupling used. The transmission elements are located between the two coupling halves [1] and [2] and are fastened by a hexagon nut [8].

The design is limited to the following sizes: 259, 285, 314, 319, 329, 341.

Variant 3

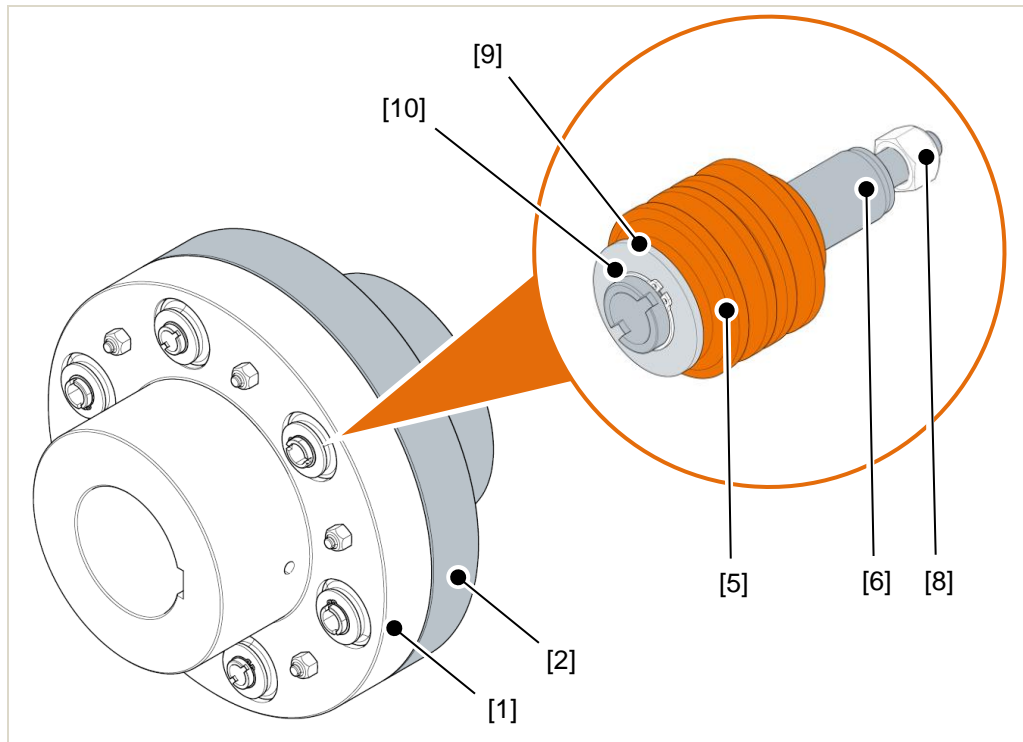

**Abb. 3 Type W**

- |                     |                     |
|---------------------|---------------------|
| [1] Coupling half   | [8] Hexagon nut     |
| [2] Coupling half   | [9] Disc            |
| [5] Coupling sleeve | [10] Retaining ring |
| [6] Bolt            |                     |

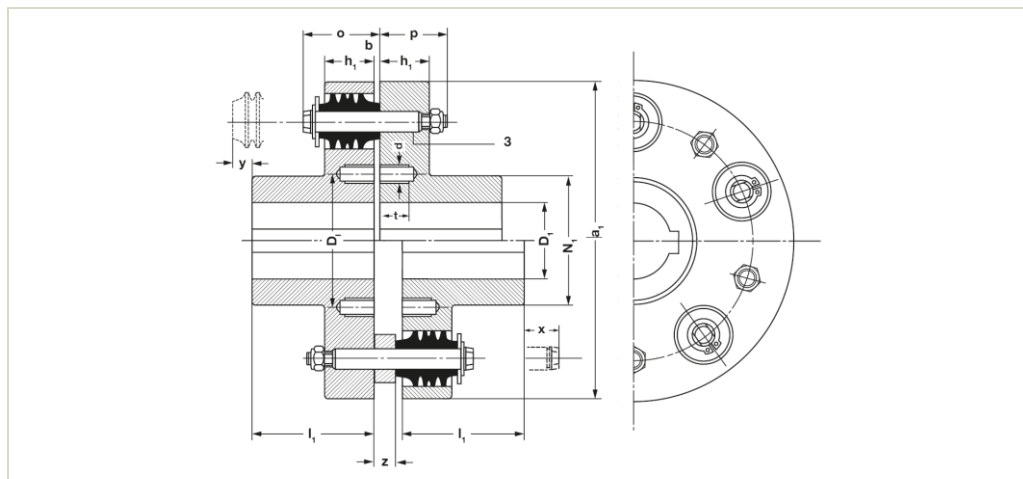

### 3.1.4 Type KWU

The KWU design describes the power plant design of transmission elements arranged on one side or alternately. The bolts [6] and the hexagon nuts [8] are especially modified for explosion-proof areas.

The transmission elements consist of the bolt [6] with a screwed-in collar, on each of which a coupling sleeve [5] is secured by a disc [9].

The design of the bolt in solid or hollow drilled design depends on the speed of the ELCO coupling used. The transmission elements are located between the two coupling halves [1] and [2] and are fastened by a hexagon nut [8].

Variant 4

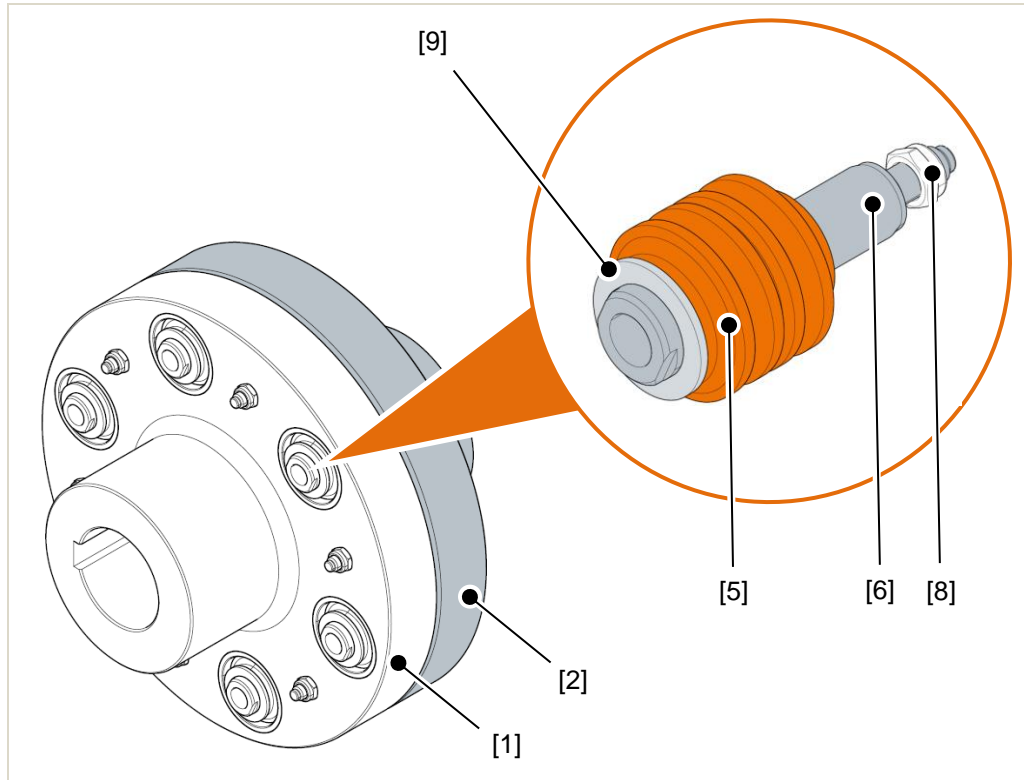

**Abb. 4 Type KWU**

- |                     |                 |
|---------------------|-----------------|
| [1] Coupling half   | [6] Bolt        |
| [2] Coupling half   | [8] Hexagon nut |
| [5] Coupling sleeve | [9] Disc        |

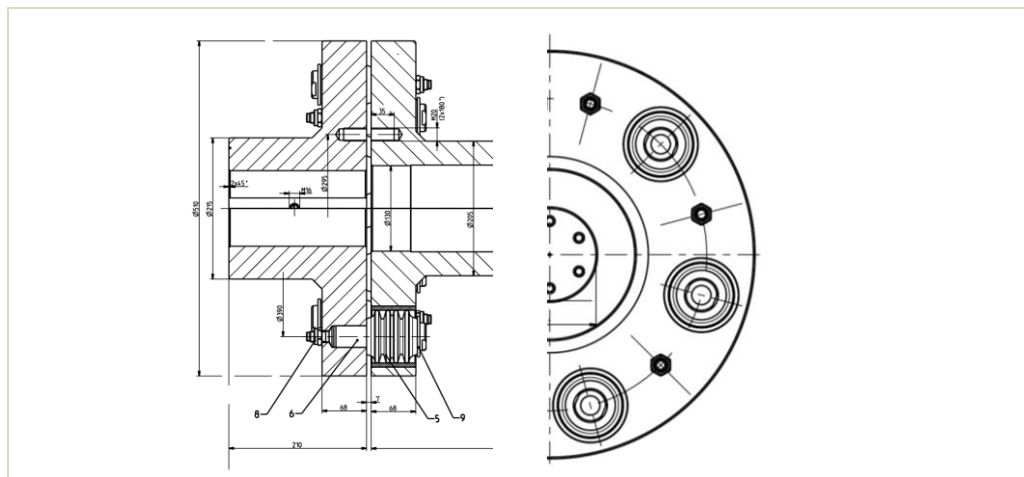

### 3.2 Type designation of the ELCO coupling

The type designation shown stands for an ELCO coupling, type **N** made of steel, without intermediate rings, bolt shape solid, sleeve type U, coupling size 247.

	N	S	O	M	U	247
<b>Series</b>						
N = Normal with transmission elements arranged on one side						
W = with transmission elements on alternating sides						
B = Break bolt coupling						
S = Normal design with brake drum or brake disc						
G = with axial play limitation						
E = with adjustable axial play						
X = special designs						
<b>Coupling material</b>						
G = grey cast iron						
K = cast iron with spheroidal graphite						
S = steel						
X = special materials						
<b>Spacers</b>						
O = without spacers						
Z = with spacers						
<b>Bolt shape</b>						
M = solid						
H = hollow drilled						
X = special versions						
<b>Sleeve material</b>						
U = modified natural rubber						
V = chloroprene polymer						
W = nitrile Rubber						
<b>Coupling size</b>						
247 = Size						

### 3.3 Technical data

#### 3.3.1 Technical data and dimensions

- The technical data and dimensions can be found in → Appendix A | Other applicable documents.

RENK

## Type N / W

Sizes 018 – 319 W



Coupling size	Coupling torque T <sub>0.95</sub> [Nm]	Max. speeds <sup>1)</sup>		Steel Flange 1 and 2													
		I [rpm]	II [rpm]	a <sub>1</sub> [mm]	l <sub>1</sub> , l <sub>2</sub> [mm]	b <sub>max</sub> <sup>2)</sup> [mm]	z	h <sub>1</sub> , h <sub>2</sub> [mm]	o [mm]	p [mm]	D <sub>1</sub> <sup>3)</sup> [mm]	d <sup>4)</sup>	t <sup>5)</sup> [mm]	x <sup>3)</sup> [mm]	x <sup>6)</sup> [mm]	y <sup>4)</sup> [mm]	
018	18 · 10 <sup>3</sup>	6000	—	87	30	6	—	21	30	—	40	M 6	12	28	—	28	
036	36 · 10 <sup>3</sup>	6000	—	97	35	6	—	21	30	—	50	M 8	15	25	—	25	
044	44 · 10 <sup>3</sup>	6000	—	112	40	6	—	26	36	—	60	M 8	15	30	—	30	
066	66 · 10 <sup>3</sup>	6000	—	130	50	6	—	26	36	—	70	M 8	15	20	—	20	
098	98 · 10 <sup>3</sup>	3600	5600	160	60	4	16	30	46	42	80	M 10	20	25	40	25	
113	13 · 10 <sup>4</sup>	3000	5000	190	75	4	16	30	46	42	100	M 10	20	10	25	10	
123	23 · 10 <sup>4</sup>	2650	4500	225	90	5	20	37	54	49	115	M 12	25	10	25	15	
129	29 · 10 <sup>4</sup>	2250	4000	270	100	6	20	45	63	61	125	M 12	25	20	35	20	
149	49 · 10 <sup>4</sup>	2000	3600	300	120	6	20	45	63	61	145	M 12	25	5	15	0	
161	61 · 10 <sup>4</sup>	1800	3300	340	140	6	25	55	74	73	170	M 16	30	5	20	0	
184	84 · 10 <sup>4</sup>	1650	3000	380	160	6	25	55	74	73	185	M 20	35	0	0	0	
210	10 · 10 <sup>5</sup>	1500	2800	440	180	7	25	68	90	92	205	M 20	35	0	10	0	
214	14 · 10 <sup>5</sup>	1250	2500	500	200	7	25	68	90	92	225	M 20	35	0	0	0	
215	15 · 10 <sup>5</sup>																
222	22 · 10 <sup>5</sup>																
228	28 · 10 <sup>5</sup>																
231	31 · 10 <sup>5</sup>																
237	37 · 10 <sup>5</sup>																
247	47 · 10 <sup>5</sup>																
259 W	59 · 10 <sup>5</sup>																
271	71 · 10 <sup>5</sup>																
285 W	85 · 10 <sup>5</sup>																
311	11 · 10 <sup>6</sup>																
314 W	14 · 10 <sup>6</sup>																
316	16 · 10 <sup>6</sup>																
319 W	19 · 10 <sup>6</sup>																

1) For maximum speed II, from size 149 on only steel couplings with hollow bolts must be used.

2) Standard fitting dimension  $b_{max} = 1/2 b_{nom}$ .

3) Space required for driving out the transmission bolts: x = for couplings without intermediate ring, x<sup>6)</sup> = for couplings with intermediate ring.

4) y = space required for removing the compression sleeves.

5) The intermediate ring is made of steel.

6) With adjusting screw up to size 237 on request - from size 247 on adjusting screw are provided as standard.

Abb. 5 Technical data and dimensions | Type N/W, sizes 018 – 319 W



Abb. 6 Technical data and dimensions | Type N/W, sizes 018 – 319 W

**RENK**

**Type N / W**  
Sizes 324 – 454

Coupling size	Coupling torque $T_{KN}$ [Nm]	Max. speeds <sup>1)</sup>		Steel Flange 1 and 2															
		I [rpm]	II [rpm]	$a_1$ [mm]	$l_1$ [mm]	$l_2$ [mm]	$b_{mm}^{2)}$ [mm]	$z$ [mm]	$h_1$ [mm]	$h_2$ [mm]	$f$ [mm]	$o$ [mm]	$p$ [mm]	$D_1$ [mm]	$d$	$t$ [mm]	$x, x^{* 3)}$ [mm]	$y^{4)}$ [mm]	
324	$24 \cdot 10^3$	1120	2250	560	220	8	30	83	76	46	106	107	240/280	M 20	35	0	0		
329 W <sup>3)</sup>	$29 \cdot 10^3$								—				240						
335	$35 \cdot 10^3$	1000	2000	640	250	8	30	83	76	46	106	107	280	M 20	35	0	0		
341 W <sup>3)</sup>	$41 \cdot 10^3$								—				260						
353	$53 \cdot 10^3$	850	1750	750	280	9	30	102	93	58	127	128	300	M 24	42	0	0		
378	$78 \cdot 10^3$	750	1500	880	320	9	—	102	93	58	127	128	210 250 290 330	M 24	42	0	0		
412	$12 \cdot 10^4$	630	1300	960	350	10	—	128	115	60	158	159	240 280 320 360	M 30	55	0	0		
416	$16 \cdot 10^4$	630	1300	1040	375	10	—	128	115	60	158	159	240 280 320 360	M 30	55	0	0		
420	$20 \cdot 10^4$	560	1200	1160	400	10	—	128	115	60	158	159	260 310 360 420	M 36	65	0	0		
426	$26 \cdot 10^4$	500	1050	1210	425	12	—	160	148	75	195	200	310 360 410 440 480	M 36	65	0	0		
432	$32 \cdot 10^4$	500	1050	1285	450	12	—	160	148	75	195	200	320 400 470 510 570	M 42	75	0	0		
443	$43 \cdot 10^4$	450	890	1430	500	12	—	160	148	75	195	200	330 410 490 530 590	M 42	70	0	0		
454	$54 \cdot 10^4$	400	750	1580	560	12	—	160	148	75	195	200	370 440 510 580 650	M 48	80	0	0		

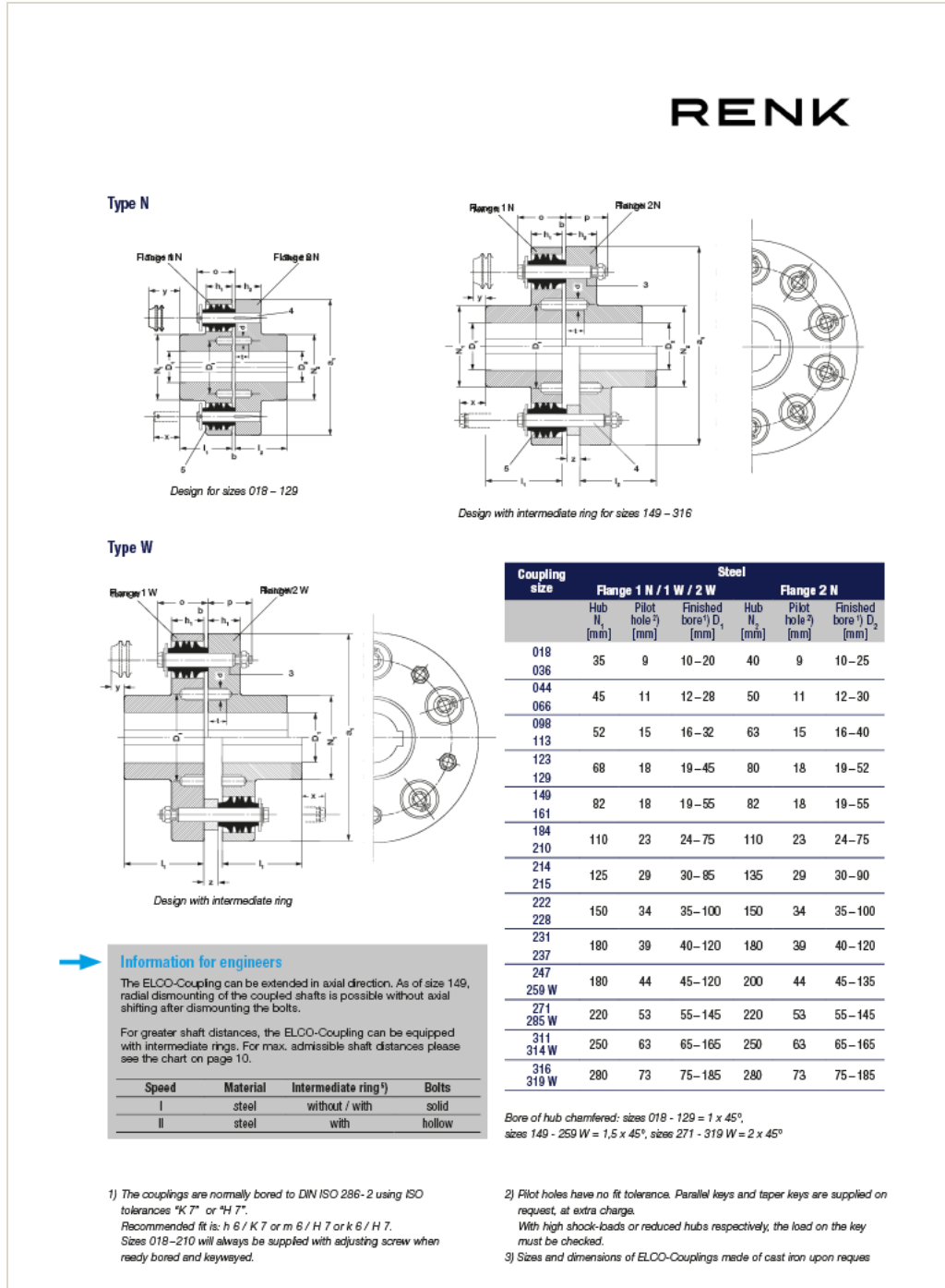
<sup>3)</sup> ELCO-Couplings type W only available in steel  
Couplings for torque higher than  $T_{KN} = 54 \cdot 10^4$  Nm are available upon request.

Observe the footnotes on pages 10 and 11.

**Abb. 7 Technical data and dimensions | Type N/W, sizes 324 – 454 W**

RENK

Type N

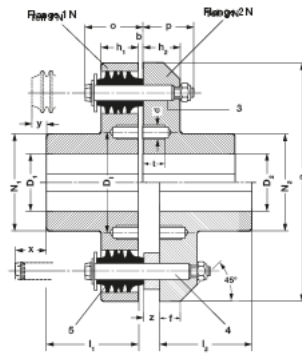

Design with intermediate ring for sizes 324–454

Bore of hub chamfered: sizes 324–353 = 2 x 45°, sizes 378–454 = 3 x 45°



Coupling size	Steel					
	Flange 1 N / 1 W / 2 W			Flange 2 N		
	Hub N <sub>1</sub> [mm]	Pilot hole <sup>2)</sup> [mm]	Finished bore <sup>1)</sup> D <sub>1</sub> [mm]	Hub N <sub>2</sub> [mm]	Pilot hole <sup>2)</sup> [mm]	Finished bore <sup>1)</sup> D <sub>2</sub> [mm]
324	290		95–190	335		95–220
329 W	275	on request	85–180	—	on request	—
335	335		110–220	365		110–240
341 W	305	on request	95–200	—	on request	—
353	365	on request	140–240	380	on request	140–250
378	245		125–160	245		125–160
	305	on request	> 160–200	305	on request	> 160–200
	365		> 200–240	365		> 200–240
	380		> 240–250	425		> 240–280
412	275		140–180	275		140–180
	335	on request	> 180–220	335	on request	> 180–220
	395		> 220–260	395		> 220–260
	425		> 260–280	485		> 260–320
416	275		140–180	275		140–180
	335	on request	> 180–220	335	on request	> 180–220
	395		> 220–260	395		> 220–260
	450		> 260–300	485		> 260–320
420	305		160–200	305		160–200
	380	on request	> 200–250	380	on request	> 200–250
	450		> 250–300	450		> 250–300
	485		> 300–320	545		> 300–360
426	350		180–230	350		180–230
	425	on request	> 230–280	425	on request	> 230–280
	500		> 280–330	500		> 280–330
	545		> 330–360	545		> 330–360
	605		> 360–400	605		> 360–400
432	360		190–240	360		190–240
	450	on request	> 240–300	450	on request	> 240–300
	530		> 300–350	530		> 300–350
	570		> 350–380	570		> 350–380
	640		> 380–425	640		> 380–425
443	380		200–250	380		200–250
	470	on request	> 250–310	470	on request	> 250–310
	560		> 310–370	560		> 310–370
	605		> 370–400	605		> 370–400
	680		> 400–450	680		> 400–450
454	410		220–270	410		220–270
	500	on request	> 270–330	500	on request	> 270–330
	590		> 330–390	590		> 330–390
	680		> 390–450	680		> 390–450
	760		> 450–500	760		> 450–500

2) If not otherwise expressly specified, we supply coupling halves with a pilot hole 5 mm smaller in diameter than the desired finished bore size.

With enquiries or when ordering please state:

1. Type of coupling
2. Bore D in mm and tolerances for both flanges
3. Connection of shaft/hub
4. Kind of driving and driven machine
5. Maximum power to be transmitted, starting torque and magnitude of shock loads
6. Moments of inertia of driving and driven machine
7. Speed in rpm
8. Type of compression sleeves (U, V, W)
9. Ambient temperature
10. Frequency of engagements/disengagements

**Information for engineers**

The ELCO-Coupling can be extended in axial direction. As of size 149, radial dismounting of the coupled shafts is possible without axial shifting after dismounting the bolts.

For greater shaft distances, the ELCO-Coupling can be equipped with intermediate ring spacers. For max. admissible shaft distances please see the chart on page 12.

Speed	Material	Intermediate ring <sup>2)</sup>	Bolts
I	steel	without / with	solid
II	steel	with	hollow

Abb. 8 Technical data and dimensions | Type N/W, sizes 324 – 454 W

### 3.3.2 Weights

- Information about the weights can be found in the → Appendix A | Other applicable documents.

RENK

## Weights [kg]

Values refer to nominal diameter of the bores and the hub diameter, corresponding to the bores.  
All values refer to steel as material of the couplings.

Flange 2: - including transmission components.  
Type W: - flange 1 and flange 2 including their transmission components.

Coupling size	Nom. dia. [mm]	For all Types		Type N / W		Type B		Intermediate ring
		Flange 1	Flange 2	Flange 1 + 2	Flange 2 / 12	Flange 1 + 2 / 12		
018	10	0,93	1,1	2,03	—	—	—	
036	—	0,85	1,15	2,0	—	—	—	
044	20	1,1	1,5	2,6	—	—	—	
066	—	1,0	1,55	2,55	—	—	—	
098	30	1,4	2,8	4,2	—	—	—	
113	—	1,2	2,9	4,1	—	—	—	
123	40	2,1	3,6	5,7	—	—	—	
129	—	1,9	3,7	5,6	—	—	—	
149	50	3,6	5,9	9,5	10,2	13,8	0,4	
161	—	3,2	6,0	9,2	—	—	0,5	
184	60	6,5	9,5	16	15	21,5	0,5	
210	—	6,1	9,6	15,7	—	—	0,6	
214	70	10	15,5	25,5	25,8	35,8	0,7	
215	—	9,9	15,5	25,4	—	—	0,8	
222	80	18,5	26,0	44,5	44	63	1,0	
228	—	17	26,5	43,5	—	—	1,3	
231	90	27	37	64	55	82	1,3	
237	—	26	37	63	—	—	1,6	
247	100	37	55	91	83	120	2,1	
259 W	—	43	43	88	—	—	2,6	
271	110	55	73	128	108	163	2,6	
285 W	—	63	63	126	—	—	3,1	
311	120	87	116	203	170	257	3,5	
314 W	—	100	100	200	—	—	4,4	
316	140	118	154	272	236	354	4,4	
319 W	—	134	134	268	—	—	5,3	
324	160	146	224	370	350	496	7,4	
329 W	—	169	169	338	—	—	8,9	
335	180	215	300	515	470	685	8,9	
341 W	—	232	232	464	—	—	10,4	
353	200	346	455	807	660	1006	10,4	
378	220	397	518	915	—	—	—	
412	240	545	780	1325	—	—	—	
416	260	550	810	1360	—	—	—	
420	280	780	1050	1830	—	—	—	
426	300	1050	1460	2510	—	—	—	
432	320	1160	1660	2820	—	—	—	
443	350	1500	2080	3560	—	—	—	
454	400	2340	3150	5490	—	—	—	

*For designs with an intermediate ring, the coupling weights are to be increased by the weight of the intermediate ring which is listed separately.*

*In case of separate calculation, the weight of the intermediate ring is to be added to that of flange 2 or flange 2/12*

*The weight of the intermediate ring refers to one set.*

Type S		
Brake drum Flange 12 ∅ [mm]	Width [mm]	[kg]
200	75	5,0
250	95	8,25
315	118	14,6
400	150	28,6
500	190	51
630	236	93
710	265	124
800	300	169

*The weights of the coupling are the same as those of type N.*

*By adding the weights of the brake drum and of flange 2 of the ELCO-Coupling type N you obtain the weight of flange 2/12.*

Abb. 9 Weights

## 4 Transport and storage

### **WARNING**

#### **Serious injuries due to falling or toppling loads!**

There is a risk that body parts will be crushed due to falling or toppling loads.

- ▶ Secure transport routes. Transport routes must be free of persons and objects.
- ▶ Never stand under suspended loads.
- ▶ Wear safety shoes, safety helmet and safety gloves.
- ▶ Make sure that load-bearing and lifting equipment corresponds to the weights of the loads.
- ▶ Load-bearing and lifting equipment may only be attached to the attachment points provided for this purpose.
- ▶ Secure loads against slipping or tipping.

The ELCO coupling is supplied in standard packaging. Individual components may be packed separately to avoid transport damage

The coupling half [1] and the coupling half [2] are shipped in the assembled state. The existing threaded holes (lifting threads) are not closed. From size 353, the transmission elements are assembled, but the ELCO coupling halves are not assembled.

ELCO couplings with pilot holes are always supplied unassembled.

### 4.1 Condition of delivery

#### Check delivery

- ▶ Check the complete scope of delivery based on the delivery note and the packing list and report deviations from the scope of delivery in writing, for example by e-mail, to the service department immediately after receipt of the delivery.
- ▶ Check the delivery for any damage (visual inspection) and note this on the forwarder's delivery bill. Report any damage immediately to the last carrier and the service department → Contact, page 2.
- ▶ Check the corrosion protection after opening the transport packaging. If the corrosion protection is damaged, see → chapter 4.4.2, page 28.
- ▶ Keep the packaging in case the carrier needs to check it or the packaging is needed for return transport.
- ▶ If parts are so severely damaged that a return is required, contact the service department beforehand, → Contact, page 2.
- ▶ If necessary, pack the delivery for return to prevent any further damage occurring during proper transport.



#### Disposing of the packaging

The packaging is tailored to the size, scope and transport route of the delivery. Dispose of the packaging in accordance with the applicable national regulations.

## 4.2 Transport

In addition to the basic safety instructions in → chapter 2, page 7, observe the following instructions to avoid transport damage:

- Principle
- ▶ Some components are supplied as loose parts. These components and further information (quantity, weight) can be found in the shipping documents.
  - ▶ Before transporting the ELCO coupling or its parts with eyebolts, make sure that the screws are tightened at the part groove, otherwise parts may come loose.
  - ▶ Where possible, keep the ELCO coupling in its original packaging until shortly before installation to avoid transport damage and contamination.
  - ▶ Use suitable fastening points or lifting threads to avoid transport damage caused by detaching components.
  - ▶ To avoid damage to the surfaces, always use round slings, lifting slings or such like and attach an edge protector. Never use wire ropes or chains.

- Lifting equipment
- ▶ Check S-hooks, eyebolts (DIN 580) and shackles before and during each use for impermissible deformations, visible cracks, in particular transverse cracks in the shaft, neck, thread or hook mouth and that the load-bearing capacity suitable for the use.
  - ▶ Determine the weight of the load and attach the lifting equipment at the intended points. Observe the load-bearing capacity with the eyebolts screwed in laterally up to an angle of inclination of a maximum of 45° in the direction of the ring plane.
  - ▶ Always screw in eyebolts completely and do not bend them, otherwise the load-bearing capacity will be reduced to 25%. Eyebolts stressed by bending may break off. If necessary, use a load block or a screw-in swivel.
  - ▶ Unscrew twisted lifting equipment before lifting. Do not tension or pull lifting equipment over sharp edges. If necessary, use edge protection. Shorten or lengthen chains only with approved components.



Abb. 10 Diagonal and lateral pull on eyebolts

**A** Permissible diagonal pull (angle max. 45°)

**B** Prohibited lateral pull counter to the direction of the ring plane

### 4.3 Storage

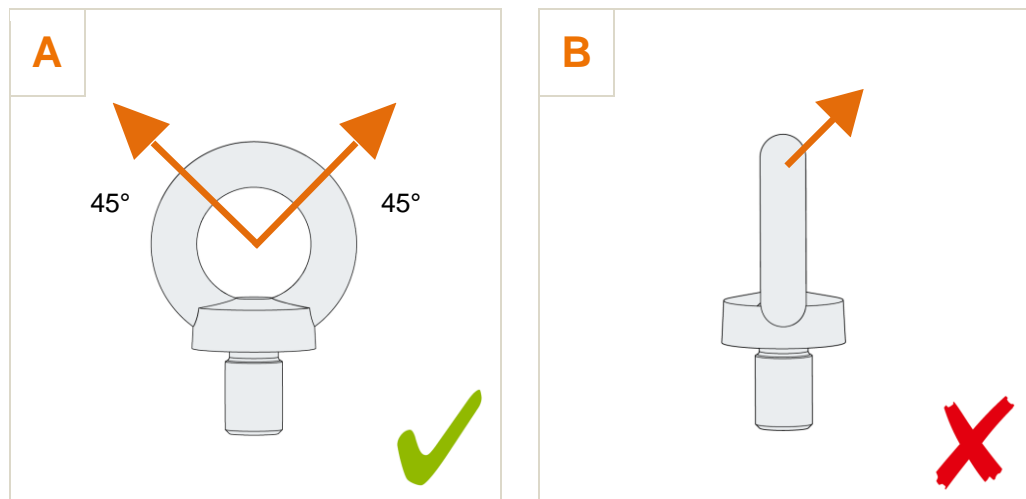
#### **ATTENTION**

If the storage time is exceeded, corrosion damage may occur to the ELCO coupling. Regularly check the ELCO coupling for corrosion if the storage time has been exceeded.

- ▶ If corrosion occurs, protect the ELCO coupling with an anti-corrosion agent according to the manufacturer's instructions. Please consult the Service Department → Contact, page 2.

Corrosive parts are preserved as standard with Anticorit DFW 9301. As a result, the ELCO coupling is protected for eighteen months when stored in an enclosed space. If the protection period is exceeded, you must preserve the ELCO coupling again, depending on the corrosion protection agent and storage location

→ Chapter 4.4.2, page 28.

- ▶ Only store the ELCO coupling in dry and temperature-controlled rooms, protected from weather, climate and other natural forces (e.g. floods or earthquakes) as well as from pest infestation.
- ▶ Never store the ELCO coupling in a humid, dusty, salty, acidic or chemical atmosphere.
- ▶ Do not remove the corrosion protection until you commence the assembly work.

#### Coupling sleeves

No corrosion protection is used for the coupling sleeves. Follow the listed instructions in order to safely store the coupling sleeves.

- ▶ Do not expose the coupling sleeves to sun, ozone or oxygen. The mechanical properties of the coupling sleeves may be impaired and damaged. Ozone and UV light significantly reinforce the ageing of the coupling sleeves.
- ▶ Use airtight and opaque packaging to store coupling sleeves. Please refer to DIN ISO 1431-3 for this purpose.

### 4.4 Corrosion protection

#### **! WARNING**

##### **Danger when handling hazardous substances!**

Improper handling of lubricating oils, corrosion protection and operating materials can lead to the loss of life and health of those affected (e.g. risk of suffocation, burns to body parts).

- ▶ Observe the safety information and instructions in the safety data sheets of the products used.
- ▶ Wear your personal protective equipment, such as protective clothing, safety gloves and tight-fitting goggles.
- ▶ Provide adequate ventilation and do not inhale the vapours. If adequate ventilation is not possible, wear respiratory protection.
- ▶ Make sure there are no sources of ignition.

#### 4.4.1 Delivery condition

Corrosive parts are preserved as standard with Anticorit DFW 9301. For long-term preservation (seaworthy packaging), the ELCO coupling is additionally vacuum-packed with a stable film and protected by a wooden box. The packaging contains a desiccant which absorbs any moisture and prevents the formation of condensation.

Anticorit DFW 9301 is a solvent-free anti-corrosion agent that is also free of barium. The anti-corrosion agent has a viscosity similar to water and also penetrates into smaller joints. After application, Anticorit DFW 9301 forms a thin, greasy wax-like, non-hardening protective film. The clear, champagne-coloured film is soluble in small quantities in mineral lubricants without affecting the lubricant → Annex B | Safety data sheets.

Tectyl 506 EH is used if stronger corrosion protection is required → chapter 4.5, page 31.

Duration of protection

The information provided by the customer determines which corrosion protection the ELCO coupling receives. The following table shows an overview of the corrosion protection period for each type of preservation.

Storage place	Corrosion protector	Period [month]			
		6	18	36	48
In an enclosed space	1 Anticorit DFW 9301		x		
	2 Anticorit DFW 9301, components packed airtight in plastic bag/film				x
	3 Tectyl 506 EH				x
Under a roof or in an open shed	1 Anticorit DFW 9301	x			
	2 Anticorit DFW 9301, components packed airtight in plastic bag/film			x	
	3 Tectyl 506 EH			x	
Outdoors	1 Anticorit DFW 9301*				
	2 Anticorit DFW 9301, components packed airtight in plastic bag/film*				
	3 Tectyl 506 EH		x		

\* It is not recommended to store the ELCO coupling under open roofs or outdoors, as the necessary integrity of the protective films cannot be guaranteed (mechanical influences; weather influences such as ice formation, hail, UV radiation; damage through insects or animals feeding).

#### 4.4.2 Inspection

Follow the listed instructions if the ELCO coupling is provided with long-term preservation (seaworthy packaging).

- At reception
- ▶ Check the foil of the packaging. The packaging must still be undamaged and in a vacuum condition.
  - ▶ Opening the packaging, for example, for incoming goods inspection, is permitted. Nevertheless, it is absolutely crucial to then restore this packaging professionally in accordance with the desired corrosion protection period.
  - ▶ Notify the service → Contact, page 2, if you notice any damage to the packaging or improper preservation of the ELCO coupling. In this case, the corrosion protection will not be sufficient.

- During the protection period
- ▶ It is recommended to check the integrity of the packaging at regular intervals.
  - ▶ If the vacuum packaging is undamaged, there is no need to check the ELCO coupling during the corrosion protection period.

- End of the term of protection
- The end of the term of protection is reached after the packaging has been opened or after the term of protection for the relevant type of preservation has been exceeded.
- ▶ Open the transport packaging.
  - ▶ Inspect the interior of the ELCO coupling if corrosion is detected on the external surfaces during an inspection. Use the inspection holes as indicated in the dimensional drawing.
  - ▶ Take photos to document the inspection results.

Results	Exterior surfaces	Inner surfaces
No corrosion	If no corrosion is visible, the corrosion protection is sufficient.	If no corrosion is visible, the corrosion protection is sufficient.
Light corrosion	Remove any minor corrosion before commencing re-preservation. <ul style="list-style-type: none"> <li>• Remove the corrosion.</li> <li>• Check the inner surfaces.</li> <li>• Preserve the ELCO coupling again.</li> </ul>	Remove any minor corrosion before commencing re-preservation. <ul style="list-style-type: none"> <li>• Disassemble the ELCO coupling.</li> <li>• Remove the corrosion.</li> <li>• Preserve the ELCO coupling again.</li> </ul>
More significant corrosion	Notify the service → Contact, page 2.	Notify the service → Contact, page 2.

#### 4.4.3 Post-preservation

##### **ATTENTION**

Remove any corrosion that has been detected before re-preserving the ELCO coupling. The ELCO coupling may be severely damaged. Contact the Service Department → Contact, page 2.

##### **ATTENTION**

###### **Damage to the coupling sleeves!**

Solvents and anti-corrosion agents may damage the coupling sleeves and change the mechanical properties of the coupling sleeve.

- ▶ Make sure that the coupling sleeves do not come into contact with solvents and anti-corrosion agents.

- ▶ Use the anti-corrosion agent according to the safety instructions and the manufacturer's instructions for use.
- ▶ When renewing the preservation, contact with the anti-corrosion agent may occur. Corrosion inhibitors contain mineral oil. No special hazards are known, as long as the usual precautions and personal protective equipment are observed when handling mineral oil products. Ventilate rooms thoroughly during preservation.
- ▶ Corrosion inhibitors containing mineral oil are generally flammable, may form flammable vapour-air mixtures and are water-polluting.
- ▶ Do not use anti-corrosion agent on synthetic materials (e.g. cables, hose lines). In individual cases, plastics may not be resistant to corrosion inhibitors.
- ▶ Parts can be coated with Anticorit DFW 9301 by brushing, dipping or spraying. The surfaces must be clean and free from grease.

Mounted ELCO coupling

To protect an ELCO coupling that is mounted in a complete system from corrosion, proceed as follows:

- ▶ Perform an inspection through → chapter 4.4.2, page 28.
- ▶ Clean the ELCO coupling → chapter 7.4, page 56.
- ▶ Brush or spray all bare metal parts inside and out with an anti-corrosion agent, for example with Anticorit DFW 9301.
- ▶ Mount the ELCO coupling → chapter 4.4, page 26.
- ▶ Close off all connection holes of the corresponding fittings with screw plugs.
- ▶ Seal all gaps with self-adhesive, permanent adhesive tape.

Storage time until commissioning

If it is known that storage for multiple years is to be expected before commissioning, it is recommended to disassemble the internal parts and preserve the components individually.

- ▶ Disassemble the ELCO coupling completely.
- ▶ Spray or paint all components of the ELCO coupling with anti-corrosion agent.
- ▶ Store the components of the ELCO coupling separately from each other.

#### 4.4.4 Removal

##### **ATTENTION**

##### **Damage to the coupling sleeves!**

Solvents and anti-corrosion agents may damage the coupling sleeves and change the mechanical properties of the coupling sleeve.

- ▶ Make sure that the coupling sleeves do not come into contact with solvents and anti-corrosion agents.

Anticorit DFW 9301 is easily removed by wiping or washing with aqueous industrial cleaners or solvents such as Renoclean®.

##### Inner surfaces

It is recommended to carefully remove the preservation inside the ELCO coupling when opening the ELCO coupling, although Anticorit DFW 9301 is lubricant compatible. During transport and assembly, dirt particles may also accumulate in the corrosion protection agent, thus endangering the operational safety of the ELCO coupling.

Anticorit DFW 9301 does not necessarily need to be removed from the inner surfaces of the ELCO coupling for the reasons mentioned above, unless there are requirements for assembly or suspected contamination.

##### External surfaces

For the external surfaces, it is recommended to carefully remove the anti-corrosion agent from the surfaces. During storage and transport, dust and dirt may accumulate in the protective film.

## 4.5 Additional corrosion protection

### **ATTENTION**

#### **Damage to the coupling sleeves!**

Solvents and anti-corrosion agents may damage the coupling sleeves and change the mechanical properties of the coupling sleeve.

- ▶ Make sure that the coupling sleeves do not come into contact with solvents and anti-corrosion agents.

Tectyl 506 EH is used in cases where more resistant corrosion protection is required. Anticorit DFW 9301 additionally protects the inner parts as it will penetrate into narrow slots, grooves and holes. All other surfaces are protected by Tectyl 506 EH → Annex B | Safety data sheets.

The protective film that is formed by Tectyl 506 EH is dark, amber, waxy and transparent. It must be removed before commissioning the ELCO coupling. ELCO couplings coated with Tectyl 506 EH are additionally vacuum-packed with a sturdy film. The packaging is filled with desiccant, which absorbs any moisture and prevents the formation of condensation.

**Application** Tectyl 506-EH can be applied by brushing or spraying. The surfaces must be clean, free of grease, oil and residues from previous preservations. The required layer thickness is 50 to 80 µm.

Tectyl 506-EH is not suitable for coating using dipping methods. Do not use anti-corrosion agents on synthetic materials (e.g. hoses, cables). Some synthetic materials are not solvent-resistant.

**Removal** Tectyl 506 EH can be easily removed from the parts with white spirit, turpentine, petroleum, diesel fuel or similar solvents. Removal with alkaline cleaners in a hot process or by low-pressure steam cleaning is also possible. After cleaning with alkaline cleaners, care should be taken to ensure immediate drying. The cleaning agents should contain anti-corrosion additives.

The inner and exterior surfaces must be free of Tectyl 506 EH. The anti-corrosion agent on the outer surfaces may contain dust and foreign particles during transport, which risks impairing trouble-free operation at a later stage.

## 5 Assembly

### 5.1 Warnings

#### **WARNING**

##### **Serious injuries due to unintentional rotational movement of the machine parts!**

Ejected coupling parts and being caught by rotating machine parts can lead to serious injuries.

- ▶ Switch off the coupled machine string during all work.
- ▶ Secure the control devices against unintentional switching on.
- ▶ Do not operate the coupling until it is fully assembled and all guards are ready for operation.

#### **WARNING**

##### **Danger when handling hazardous substances!**

Improper handling of lubricating oils, corrosion protection and operating materials can lead to the loss of life and health of those affected (e.g. risk of suffocation, burns to body parts).

- ▶ Observe the safety information and instructions in the safety data sheets of the products used.
- ▶ Wear your personal protective equipment, such as protective clothing, safety gloves and tight-fitting goggles.
- ▶ Provide adequate ventilation and do not inhale the vapours. If adequate ventilation is not possible, wear respiratory protection.
- ▶ Make sure there are no sources of ignition.

#### **CAUTION**

##### **Risk of burns due to heated ELCO coupling or components!**

Burns from components are possible.

- ▶ Allow the ELCO coupling and adjacent machine parts to cool down for a sufficient period of time before starting work.
- ▶ Wear suitable protective clothes.

## 5.2 Preparations

- ▶ Make sure that the workplace is completely clean. Thoroughly clean the ELCO coupling. No impurities such as screws, nuts, dirt or metal shavings may get into the ELCO coupling. If such items are left behind in the ELCO coupling, they could cause damage to the ELCO coupling.
- ▶ Remove the preservation before installation. Dirt particles may settle in the protective film during packaging and transport.
- ▶ Always lift the coupling and its parts using suitable slings and use edge protectors or anti-slip mats.
- ▶ Use only suitable tools (e.g. a rubber hammer as impact tool) and suitable devices and assembly methods to avoid burring, deformation and failure of the coupling. Never use hard impact tools, pointed or sharp tools.
- ▶ Observe the operating instructions of the manufacturers of the machines to be coupled and the devices used for assembly.
- ▶ Remove any stickers that are present on the parts.

### 5.3 Markings on the coupling

The coupling halves are marked with the size, the bore diameter and the RENK order number.

- ▶ Check that all parts and data required for assembly are available.
- ▶ Make sure to use only the coupling specified for the application and the parts belonging to that coupling.
- ▶ Assemble the coupling according to the factory markings and correctly on the sides according to the system planning.

#### 5.3.1 Coupling sleeves

The coupling sleeves are marked depending on the material. The marking is located in the edge area of the coupling sleeve:

- **U** (modified natural rubber)
- **V** (chloroprene polymer)
- **W** (nitrile rubber)

#### 5.3.2 Optional wear indicator

The ELCO coupling may be equipped with an optional wear indicator. The wear indicator indicates the working range of the ELCO coupling. This working range is characterised by the maximum permissible angle of rotation.

- ▶ During assembly, make sure that the arrow on the coupling half [1] is opposite the twist angle range [A].



Abb. 11 Optional wear indicator

## 5.4 Preparing the coupling for installation

1. Disassemble the ELCO coupling.
  2. Clean all components of the coupling with mineral spirits or nitro-based solvents → chapter 7.4, page 56.
  3. Remove the corrosion protection completely → chapter 4.4.4, page 30.
  4. Store the disassembled transmission elements as well as the coupling half [2] securely to protect them from contamination and damage.
- ✓ The coupling half [1] is ready for assembly.

## 5.5 Installing the coupling

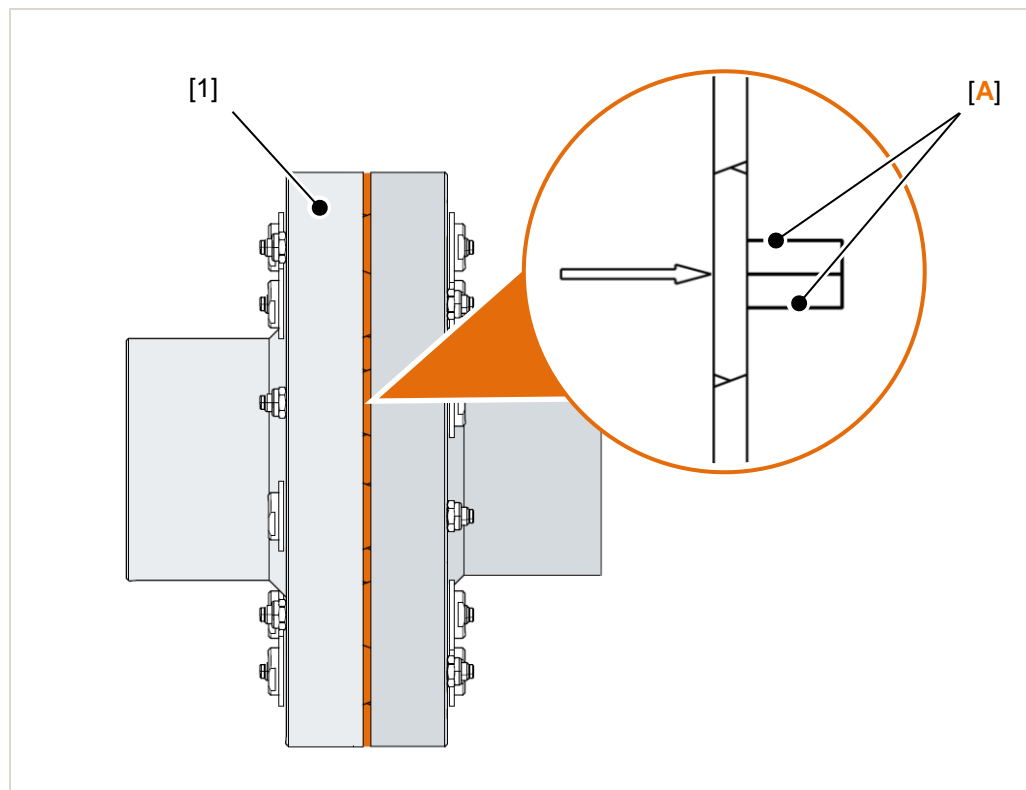
The coupling halves for the feather key connection according to DIN 6885-1 are designed for the ISO fit H7/m6 (k6) or K7/h6 (h8). Please note that a cylindrical and a tapered bore hole will require different approaches to assembly.

- ▶ Apply a thin layer of suitable assembly paste to the hub hole of the coupling half and the shaft seat before assembly.
- ▶ Once the assembly is completed, check the run-out and axial run-out of the coupling half.
- ▶ Observe the technical data for assembly, → chapter 3.3, page 19.

### 5.5.1 Tapered bore

#### **ATTENTION**

##### **Damage to the conical coupling half!**

After the thermal joining of the conical coupling half, the cooled conical coupling half must be flushed hydraulically with oil. A mineral oil ISO VG 46 must be used for this purpose. The component must not be heated with induction. There is a risk that the coating will be destroyed.

- ▶ Uniform heating is recommended, in an oven, for example.
- ▶ The system operator must perform a contact pattern check between the shaft and the conical coupling half before assembly. The contact pattern must be at least 90%.
- ▶ Make sure that the specified slide-on movement is adhered to during thermal joining. An increased slide-on distance would result in the conical coupling half not functioning as intended in the event of a malfunction.
- ▶ For tapered holes, the additional instructions for mounting on the design drawing must be observed. Mount existing shaft nuts or end washers.

### 5.5.2 Cylindrical bore

- ▶ Remove the supplied threaded pin [3] before assembly.
- ▶ Clean the bore [A] of the coupling half, the shaft and the components of the feather key connection.
- ▶ Before fitting, warm the coupling halves slightly or use a suitable fitting device.
- ▶ Make sure that the coupling half has cooled down before tightening the threaded pin [3]. Otherwise, high internal stresses may arise, which can lead to the destruction of the coupling half.
- ▶ Tighten the threaded pin [3].

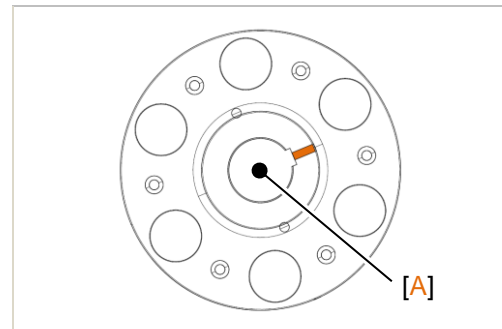
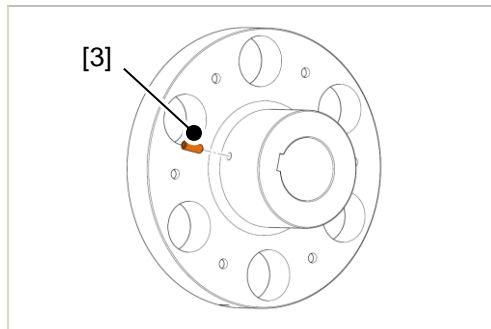

**Abb. 12 Coupling half WS, example**

[3] Threaded pin (pressure screw)

[A] Bore

## 5.6 Align shafts

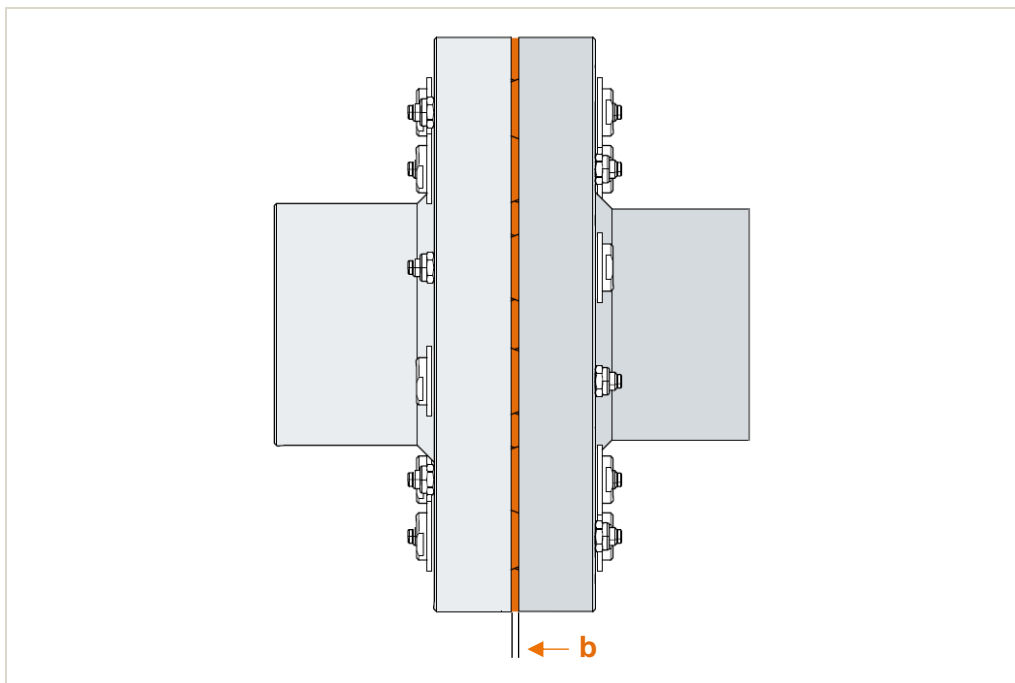

**Abb. 13 Distance between the coupling halves**

1. Adjust the distance **b** between coupling half [1] and coupling half [2]. The normal installation dimension  $b_{norm}$  should be  $0.5 * b_{max}$ .
2. Please refer to the table below for the maximum distance **b**:

Coupling size	$b_{max}$ [mm]
018 to 129	6
149 to 210	4
214 to 215	5
222 to 271	6
311 to 319	7
324 to 341	8
353 to 378	9
412 to 420	10
426 to 454	12

3. Align the shafts as precisely as possible.
  4. In order to facilitate the radial alignment of the coupling, the coupling flanges have been kept the same size. They must be flush with each other if installed correctly.
  5. Use an H-ruler on the various points of the circumference parallel to the shaft to check the distances. For permissible deviations, please refer to Technical Data  
→ Chapter 3.3, page 19.
- ✓ The shaft is aligned.

## 5.7 Permitted displacements

- ▶ Measure the angular position of the shafts using a feeler gauge (thickness gauge) in the gap between the coupling half [1] and the coupling half [2] at several points on the circumference.
- ▶ If the gap width is the same, there is no gap widening. The permissible column extension  $\Delta b$  specified as measurable variable  $\Delta b$ .

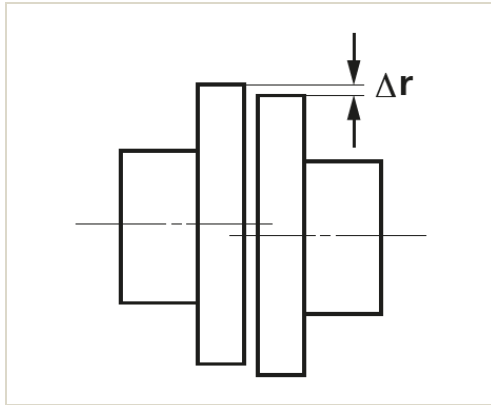

**Radial displacement  $\Delta r$**

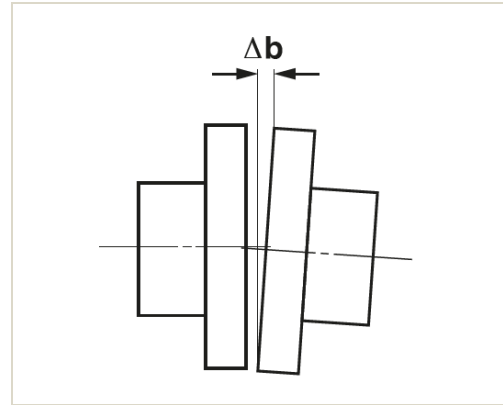

**Column widening  $\Delta b$**

Example ELCO coupling size 214 mit  $T_{KN}/T_{AN} = 2.5$  and  $n = 200 \text{ min}^{-1}$

- Permissible radial displacement:  $\Delta r = 0.25 \text{ mm}$  or
- Permissible column widening:  $\Delta b$  corresponding to  $\Delta b = 0.85 \text{ mm}$  or
- Permissible radial and gap widening: if, for example,  $\Delta b = 0.5$  is established,  $\Delta r$  can still be  $0.25 - 0.15 = 0.1 \text{ mm}$ .

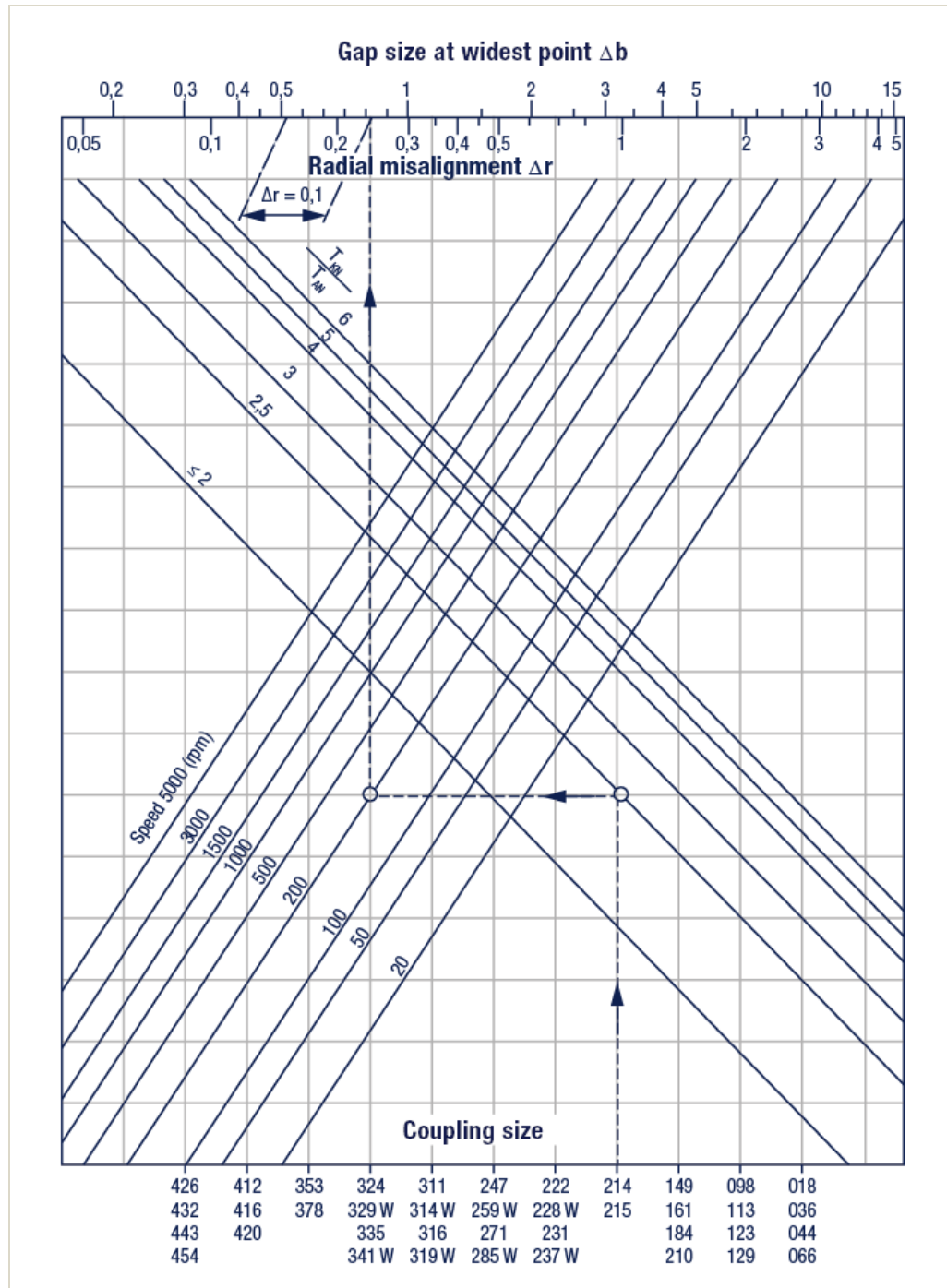

**Abb. 14 Permitted displacements**

## 5.8 Mounting transmission elements

### 5.8.1 Type N: Size 018-129

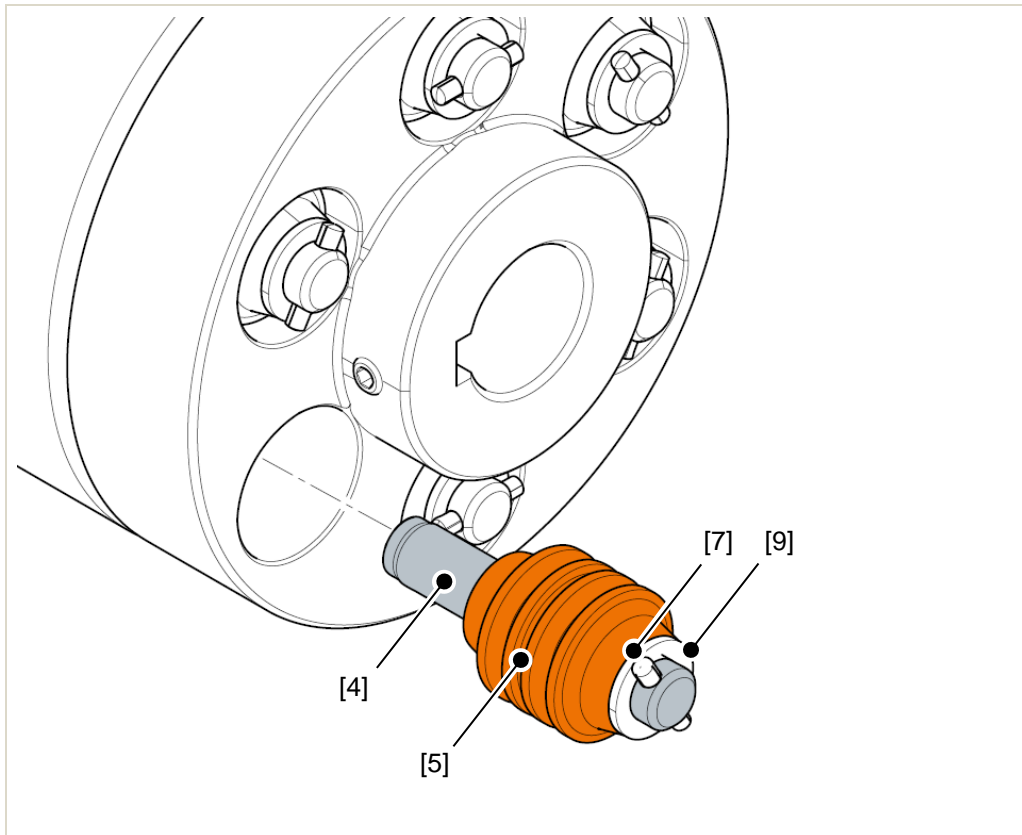

**Abb. 15 Type N: Size 018-129: Mounting transmission elements**

[4] Bolt	[7] Grooved pin
[5] Coupling sleeve	[9] Disc

1. The coupling sleeves [5] as well as the bolts [4] and the bores for receiving the coupling sleeves must not be greased or oiled.
  2. Use light blows to drive the bolts [4] with the already pre-assembled coupling sleeves [5], the grooved pins [7] and washers [9] into the greased receiving holes.
  3. After installing the transmission elements, check the distance **b** between the coupling half [1] and the coupling half [2]. The distance **b** must not exceed 6 mm ( $b_{\text{norm}} = 0.5 * b_{\text{max}}$ ) → Chapter 5.6, page 37.
- ✓ The ELCO coupling is mounted.

### 5.8.2 Type N: Size 149-454

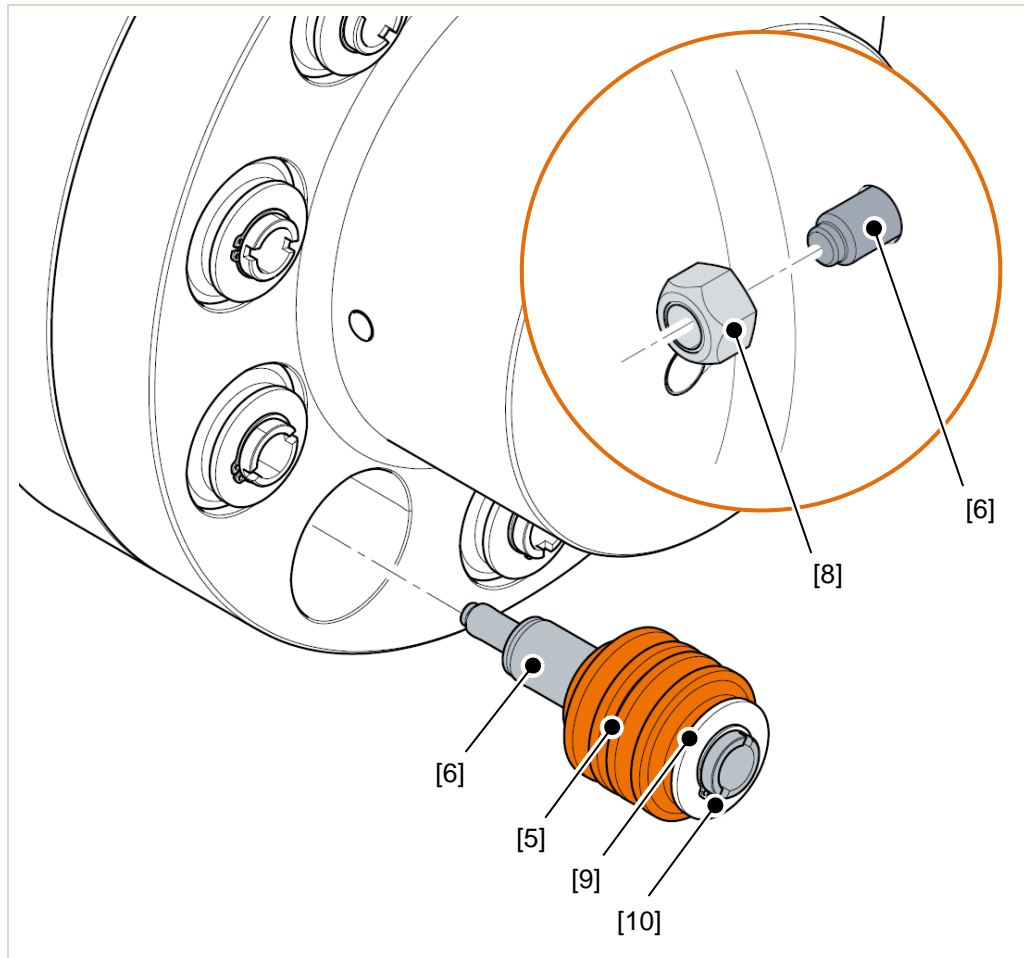

**Abb. 16 Type N: Size 149-454: Mounting transmission elements**

[5] Coupling sleeve	[9] Discs
[6] Bolt	[10] Retaining ring
[8] Hexagon nut	

1. The coupling sleeves [5] as well as the bolts [6] and the bores for receiving the coupling sleeves must not be greased or oiled.
2. Use light blows to drive the bolts [6] with the already mounted coupling sleeves [5], the washers [9] and the retaining rings [10] into the greased receiving holes.
3. Use a wrench to hold the surface at the bolt end steady so that the bolt [6] is not rotated. This prevents damage to the bolt [6] and the bore (avoidance of grooves).
4. Using the hex nuts [8], tighten the bolts [6] evenly with a torque wrench until their conical extension is in contact with the bore shoulder.

5. Please refer to the tightening torques in the following table:

Coupling size	Thread	Width across flats	Tightening torque in Nm
149 to 215	M 8	SW 13	11
222 to 237	M 10	SW 17	22
247 to 271	M 12	SW 19	39
311 to 319	M 16	SW 24	95
324 to 341	M 20	SW 30	184
353 to 378	M 24	SW 36	315
412 to 420	M 30	SW 46	635
426 to 454	M 36	SW 55	1110

6. After installing the transmission elements, check the distance **b** between the coupling half [1] and the coupling half [2], → chapter 5.6, page 37. The normal installation dimension  $b_{norm}$  should be  $0.5 \cdot b_{max}$ .

7. Please refer to the table below for the maximum distance **b**:

Coupling size	$b_{max}$ [mm]
149 to 210	4
214 to 215	5
222 to 271	6
311 to 319	7
324 to 341	8
353 to 378	9
412 to 420	10
426 to 454	12

✓ The ELCO coupling is mounted.

### 5.8.3 Type W

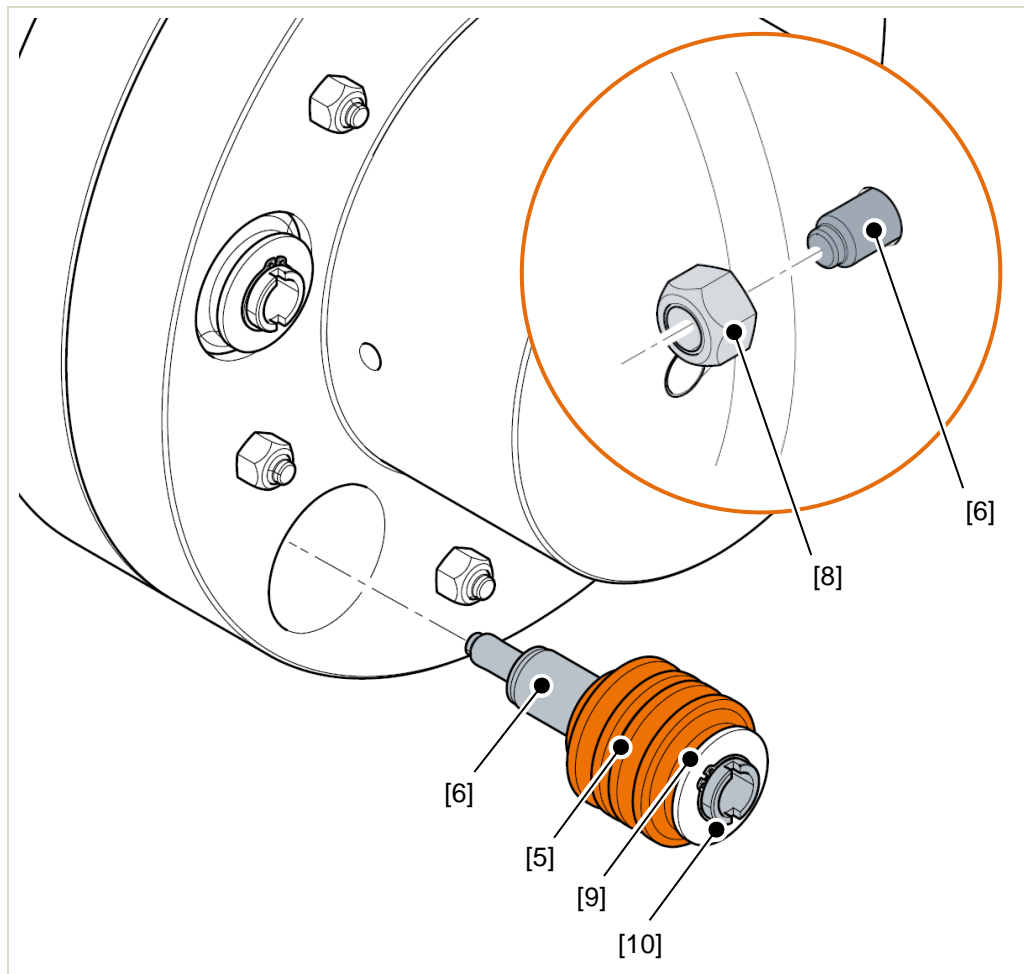

**Abb. 17 Type W: Mounting transmission elements**

[5] Coupling sleeve	[9] Disc
[6] Bolt	[10] Retaining ring
[8] Hexagon nut	

1. The coupling sleeves [5] as well as the bolts [6] and the bores for receiving the coupling sleeves must not be greased or oiled.
2. Use light blows to drive the bolts [6] with the already mounted coupling sleeves [5], the washers [9] and the retaining rings [10] into the greased alternate receiving holes.
3. Use a wrench to hold the surface at the bolt end steady so that the bolt [6] is not rotated. This prevents damage to the bolt [6] and the bore (avoidance of grooves).
4. Using the hex nuts [8], tighten the bolts [6] evenly with a torque wrench until their conical extension is in contact with the bore shoulder.

5. Please refer to the tightening torques in the following table:

Coupling size	Thread	Width across flats	Tightening torque in Nm
247 to 271	M 12	SW 19	39
311 to 319	M 16	SW 24	95
324 to 341	M 20	SW 30	184

6. After installing the transmission elements, check the distance **b** between the coupling half [1] and the coupling half [2], → chapter 5.6, page 37. The normal installation dimension  $b_{norm}$  should be  $0.5 \cdot b_{max}$ .

7. Please refer to the table below for the maximum distance **b**:

Coupling size	$b_{max}$ [mm]
222 to 271	6
311 to 319	7
324 to 341	8

✓ The ELCO coupling is mounted.

#### 5.8.4 Type KWU

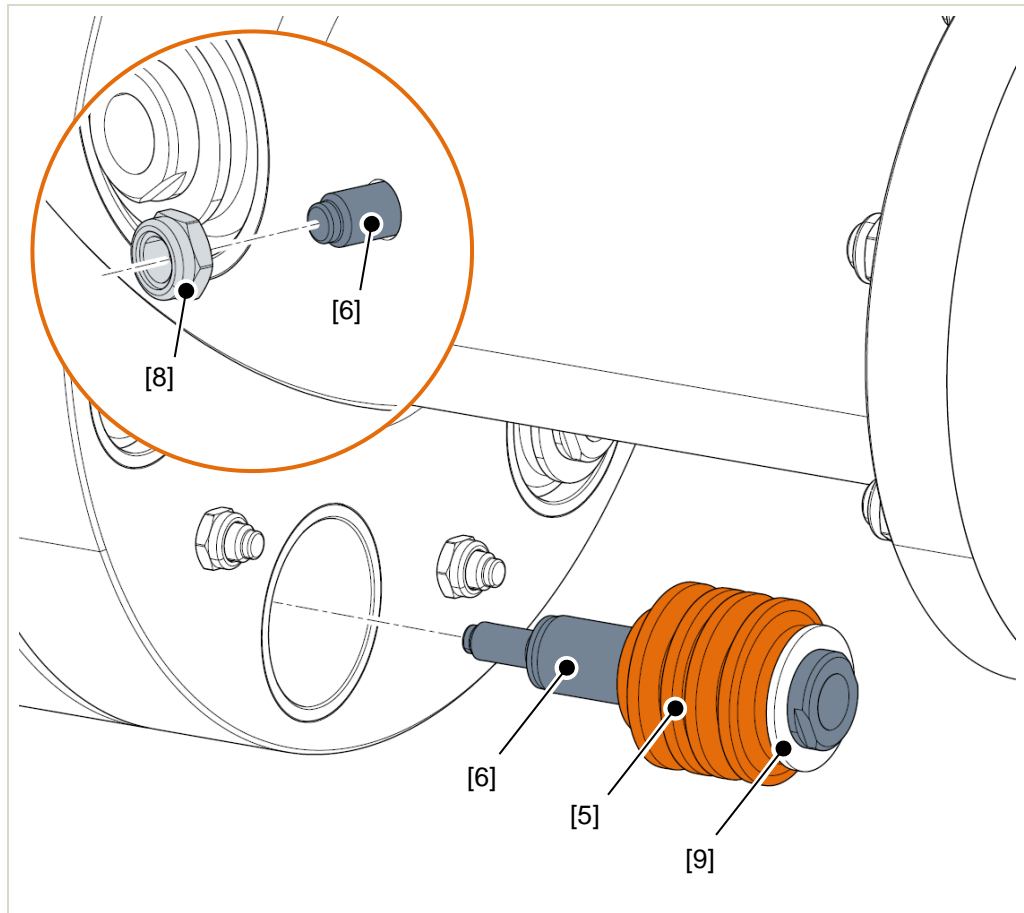

**Abb. 18 Type KWU: Mounting transmission elements**

[5] Coupling sleeve	[8] Hexagon nut
[6] Bolt	[9] Disc

1. The coupling sleeves [5] as well as the bolts [6] and the bores for receiving the coupling sleeves must not be greased or oiled.
2. Use light blows to drive the bolts [6] with the already mounted coupling sleeves [5] and the washers [9] into the greased receiving holes.
3. Use a wrench to hold the surface at the bolt end steady so that the bolt [6] is not rotated. This prevents damage to the bolt [6] and the bore (avoidance of grooves).
4. Using the hex nuts [8], tighten the bolts [6] evenly with a torque wrench until their conical extension is in contact with the bore shoulder.

5. Please refer to the tightening torques in the following table:

Coupling size	Thread	Width across flats	Tightening torque in Nm
149 to 215	M 8	SW 13	11
222 to 237	M 10	SW 17	22
247 to 271	M 12	SW 19	39
311 to 319	M 16	SW 24	95
324 to 341	M 20	SW 30	184
353 to 378	M 24	SW 36	315
412 to 420	M 30	SW 46	635
426 to 454	M 36	SW 55	1110

6. After installing the transmission elements, check the distance **b** between the coupling half [1] and the coupling half [2], → chapter 5.6, page 37. The normal installation dimension  $b_{norm}$  should be  $0.5 \cdot b_{max}$ .

7. Please refer to the table below for the maximum distance **b**:

Coupling size	$b_{max}$ [mm]
149 to 210	4
214 to 215	5
222 to 271	6
311 to 319	7
324 to 341	8
353 to 378	9
412 to 420	10
426 to 454	12

✓ The ELCO coupling is mounted.

## 6 Malfunctions

### 6.1 Warnings

#### DANGER

##### **Risk of injury as a result of improper troubleshooting!**

Improperly performed troubleshooting may cause serious injuries and considerable material damage.

- ▶ Malfunctions that require intervention may only be eliminated once it has been established that the component has come to a standstill and is secured against being switched on again.
- ▶ Only release blockages after ensuring that no dangerous movement of components occurs as a result of the release.
- ▶ Before recommissioning, observe the following:
  - Make sure that all troubleshooting work has been carried out and completed in accordance with the information in this document and the manufacturer's operating instructions.
  - Make sure that no people are present in the danger zone.
  - Make sure that all covers and safety devices are fitted and functioning properly.

#### WARNING

##### **Risk of injury from rotating or moving components!**

There is a risk of being caught or pulled in by rotating or moving components.

- ▶ Only perform work on the ELCO coupling when it is at a standstill.
- ▶ Apply a sign at the switch-on point to indicate that the ELCO coupling is being worked on.
- ▶ Before starting work, make sure that the system is free of loads.

If a defect occurs, the cause of which cannot be detected immediately, you will find important information on troubleshooting in this chapter. The following troubleshooting table can be used to locate and troubleshoot mechanical and thermal problems and defects.

The ELCO coupling should operate with low noise and vibration in all operating phases. Deviating behaviour is a malfunction that you must rectify immediately. When troubleshooting, you must always include the machines to be coupled in addition to the ELCO coupling.

Inspection and repair work may only be performed by qualified personnel for mechanical work and by qualified personnel for electrical work → Chapter 2.3, page 8.



Keep an operating log of the ELCO coupling. Carefully managed documentation of operating times, measurement results, maintenance and troubleshooting will help you understand and avoid malfunctions.

## 6.2 Troubleshooting

Malfunction	Cause	Rectification
Vibrations or noises	Unbalance	Check coupling and eliminate imbalance
	Excessive displacement	Check alignment and correct if necessary
	Coupling sleeves damaged	replace full set of coupling sleeves
Hexagon nut has loosened	wrong tightening torque	Select tightening torque in accordance with specifications
Screw torn off	wrong tightening torque	Select tightening torque in accordance with specifications
	wrong screw	Check the strength of the screw, replace the screw with an original part
	impermissibly high system torque	Reduce system torque, check system

## 6.3 Spare parts

ELCO couplings normally operate without malfunctions over long periods of use. If a problem should occur, you will find information on ordering spare parts in this chapter.

Ordering spare parts

Spare parts must meet the technical requirements specified by RENK. Original RENK spare parts always meet these requirements.

- ▶ Information about available spare parts with corresponding sizes and dimensions can be found in the → Appendix A | Other applicable documents.
- ▶ Preferably submit your spare parts orders by email. In urgent cases, the order can also be placed by telephone, as long as you confirm this immediately in writing.
- ▶ Please send your spare parts order to the RENK representative in your area or straight to our head office.
- ▶ For full contact details, see → Contact, page 2.

When ordering spare parts, please quote the following information:

ELCO coupling details

- the order number
- the material number
- the designation of the ELCO clutch

details about the spare parts

- the item number, the material number (this information is included in the parts list)
- the exact name of the spare part
- the number of spare parts needed
- desired shipping method (e.g. express, freight, air freight, courier service)

## 7 Maintenance

### 7.1 Warnings

#### DANGER

##### **Danger to life due to overrunning coupling or machine parts!**

Fatal injuries or loss of limbs are possible.

- ▶ Make sure that the drive train is secured against unintentional restart.
- ▶ Before disassembling the separating protective device, wait until the coupling and adjacent machine parts have come to a standstill.

#### DANGER

##### **Danger to life due to bursting coupling!**

Coupling parts ejected due to a bursting coupling may lead to life-threatening injuries.

- ▶ If there are any changes in the operating behaviour (e.g. noises or vibrations) or malfunctions in the coupling, stop the coupling immediately and rectify the causes.
- ▶ Check the coupling for external damage and missing parts, such as screws.

#### WARNING

##### **Serious injuries due to unintentional rotational movement of the machine parts!**

Ejected coupling parts and being caught by rotating machine parts can lead to serious injuries.

- ▶ Switch off the coupled machine string during all work.
- ▶ Secure the control devices against unintentional switching on.
- ▶ Do not operate the coupling until it is fully assembled and all guards are ready for operation.

#### WARNING

##### **Danger when handling hazardous substances!**

Improper handling of lubricating oils, corrosion protection and operating materials can lead to the loss of life and health of those affected (e.g. risk of suffocation, burns to body parts).

- ▶ Observe the safety information and instructions in the safety data sheets of the products used.
- ▶ Wear your personal protective equipment, such as protective clothing, safety gloves and tight-fitting goggles.
- ▶ Provide adequate ventilation and do not inhale the vapours. If adequate ventilation is not possible, wear respiratory protection.
- ▶ Make sure there are no sources of ignition.

**⚠ CAUTION**

**Risk of burns due to heated coupling or components!**

Burns from components are possible.

- ▶ Allow the coupling and adjacent machine parts to cool down for a sufficient period of time before starting work.
- ▶ Wear suitable protective clothes.

- Principle
- ▶ In the event of damage and any resulting warranty claims, proof of the maintenance work carried out in good time and properly must be submitted to RENK.
  - ▶ Avoid any contamination when loosening and disassembling components.
  - ▶ Before starting work, the ELCO coupling and the connected components/assemblies of the system must meet the following conditions:
    - cooled down
    - electrically de-energised
    - pressure-free
    - mechanically safe at standstill
    - secured against unintentional restarting

## 7.2 Maintenance schedule

In order to reduce wear and tear and to avoid failures and malfunctions, you must carry out the maintenance and repair work described in this chapter.

Personnel qualifications

Inspection, repair and maintenance work may only be carried out by qualified personnel for mechanical work and by qualified personnel for electrical work → Chapter 2.3, page 8.

Coupling sleeves

The ELCO coupling is equipped with paraffinised coupling sleeves [5] from which the paraffin gradually escapes to protect against natural ageing and to lubricate the bolts and bores during operation. As a result, the coupling sleeves [5] may take on a grey colouration, which, however, does not affect the service life and mode of operation.

- ▶ Perform a visual inspection of the coupling sleeves [5] every 6 months.
- ▶ In the event of damage or permanent deformation, replace the full set of coupling sleeves [5].
- ▶ Replace the full set of coupling sleeves [5] when the wear indicator has reached its maximum.
- ▶ Due to natural wear and tear as well as the stress caused by operation, the full set of coupling sleeves [5] must be replaced after 24 months.

Maintenance schedule

Special maintenance of the coupling halves [1], [2] is not required.

Interval	Maintenance activity
1 month	Visual inspection of the optional wear indicator
6 months	Visual inspection of the coupling sleeves [5] for damage or deformations
2 years	Replacement of the full set of coupling sleeves [5]

## 7.3 Replacing the coupling sleeves

### 7.3.1 Type N: Size 018-129

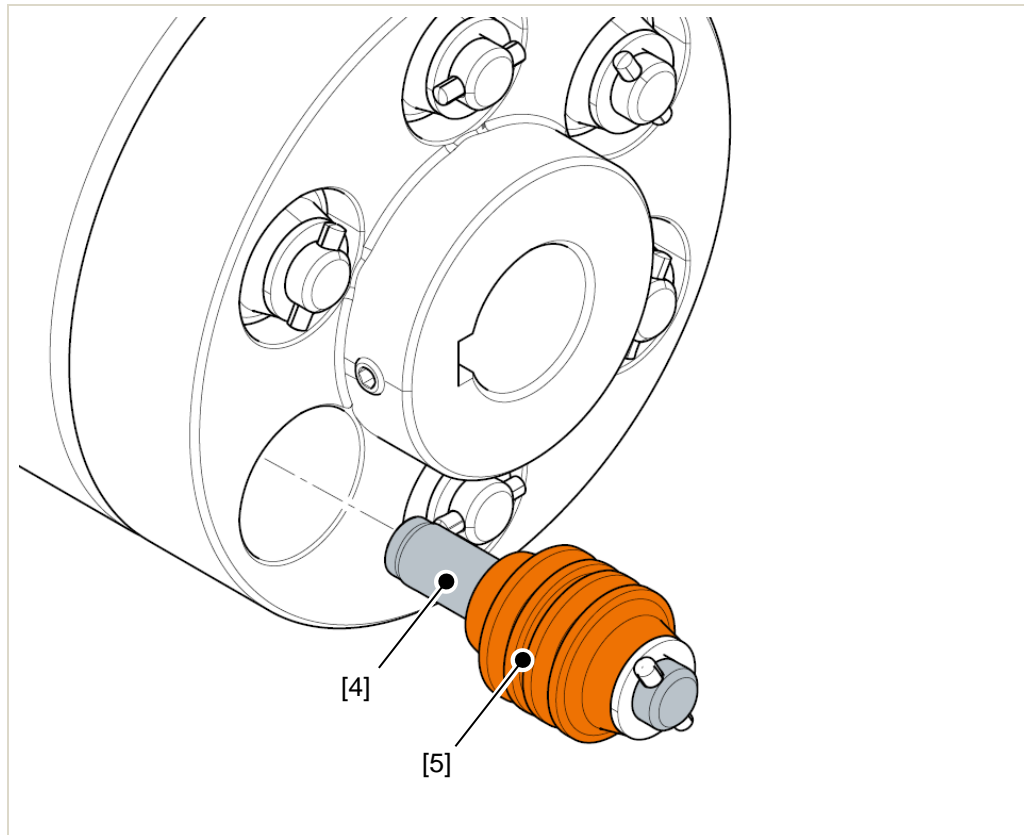

**Abb. 19 Type N: Size 018-129: Replacing coupling sleeves**

[4] Bolt

[5] Coupling sleeve

In order to achieve uniform power transmission, the full set of coupling sleeves [5] must always be replaced.

1. Disassemble the transmission elements. Remove the bolt [4] with the coupling sleeve [5].
  2. Pull the worn coupling sleeve off the bolt [4].
  3. Before reassembling, clean the bolts [4] and the receiving holes for the bolts [4] and sleeve holes.
  4. Replace the coupling sleeve [5].
  5. Repeat the instructions until all coupling sleeves [5] have been replaced.
- ✓ Finally, assemble the transmission elements. Follow the instructions listed in chapter → chapter 5.8.1, page 40.

### 7.3.2 Type N: Size 149-454

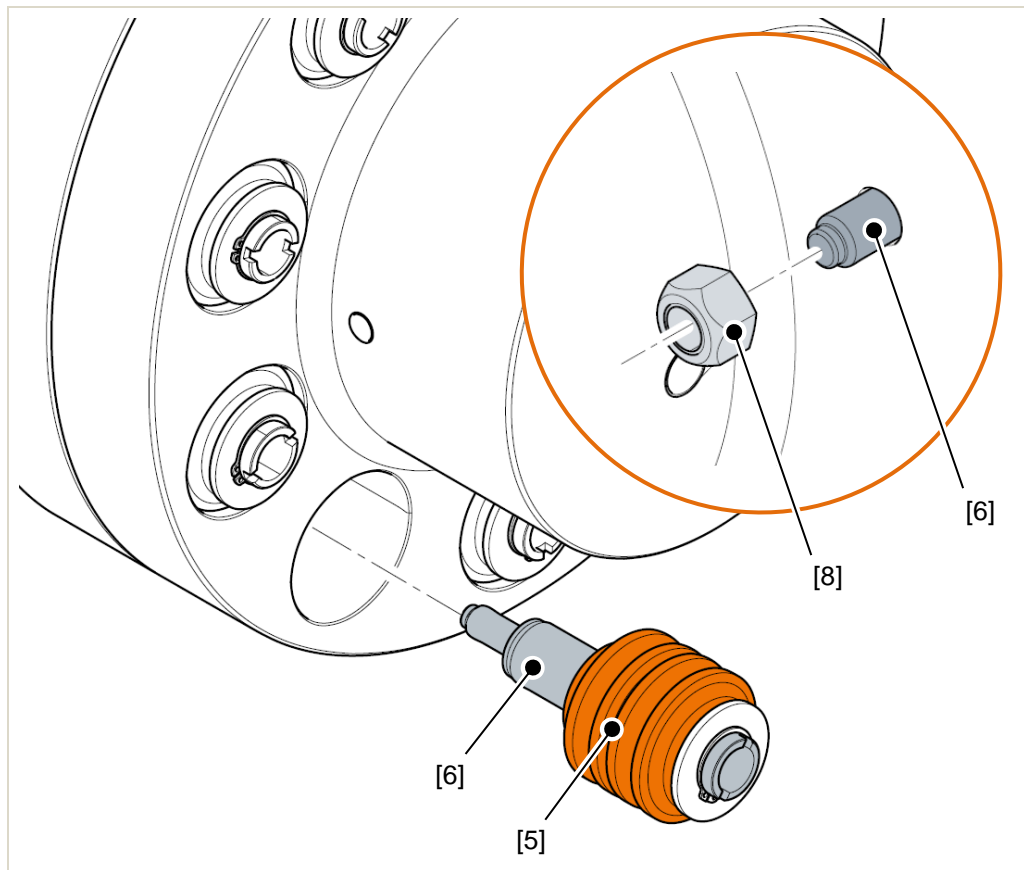

**Abb. 20 Type N: Size 149-454: Replacing coupling sleeves**

- [5] Coupling sleeve  
[6] Bolt  
[8] Hexagon nut

In order to achieve uniform power transmission, the full set of coupling sleeves [5] must always be replaced.

1. Loosen and remove the hexagon nut [8].
  2. Disassemble the transmission elements. Remove the bolt [6] with the coupling sleeve [5].
  3. Pull the worn coupling sleeve off the bolt [6].
  4. Before reassembling, clean the bolts [6] and the receiving holes for the bolts [6] and sleeve holes.
  5. Replace the coupling sleeve [5].
  6. Repeat the instructions until all coupling sleeves [5] have been replaced.
- ✓ Finally, assemble the transmission elements. Follow the instructions listed in chapter → chapter 5.8.2, page 41.

### 7.3.3 Type W

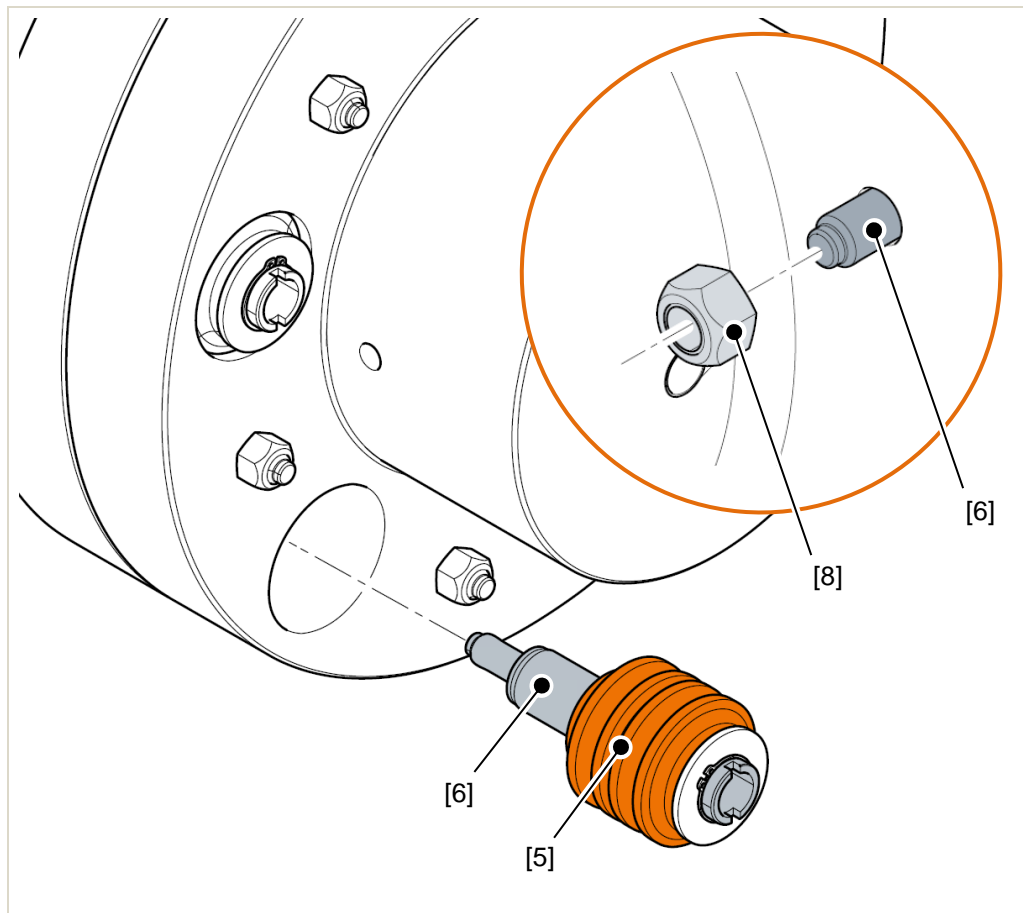

**Abb. 21 Type W: Replacing coupling sleeves**

- |                     |                 |
|---------------------|-----------------|
| [5] Coupling sleeve | [8] Hexagon nut |
| [6] Bolt            |                 |

In order to achieve uniform power transmission, the full set of coupling sleeves [5] must always be replaced.

1. Loosen and remove the hexagon nut [8].
  2. Disassemble the transmission elements. Remove the bolt [6] with the coupling sleeve [5].
  3. Pull the worn coupling sleeve off the bolt [6].
  4. Before reassembling, clean the bolts [6] and the receiving holes for the bolts [6] and sleeve holes.
  5. Replace the coupling sleeve [5].
  6. Repeat the instructions until all coupling sleeves [5] have been replaced.
- ✓ Finally, assemble the transmission elements. Follow the instructions listed in chapter → chapter 5.8.3, page 43.

### 7.3.4 Type KWU

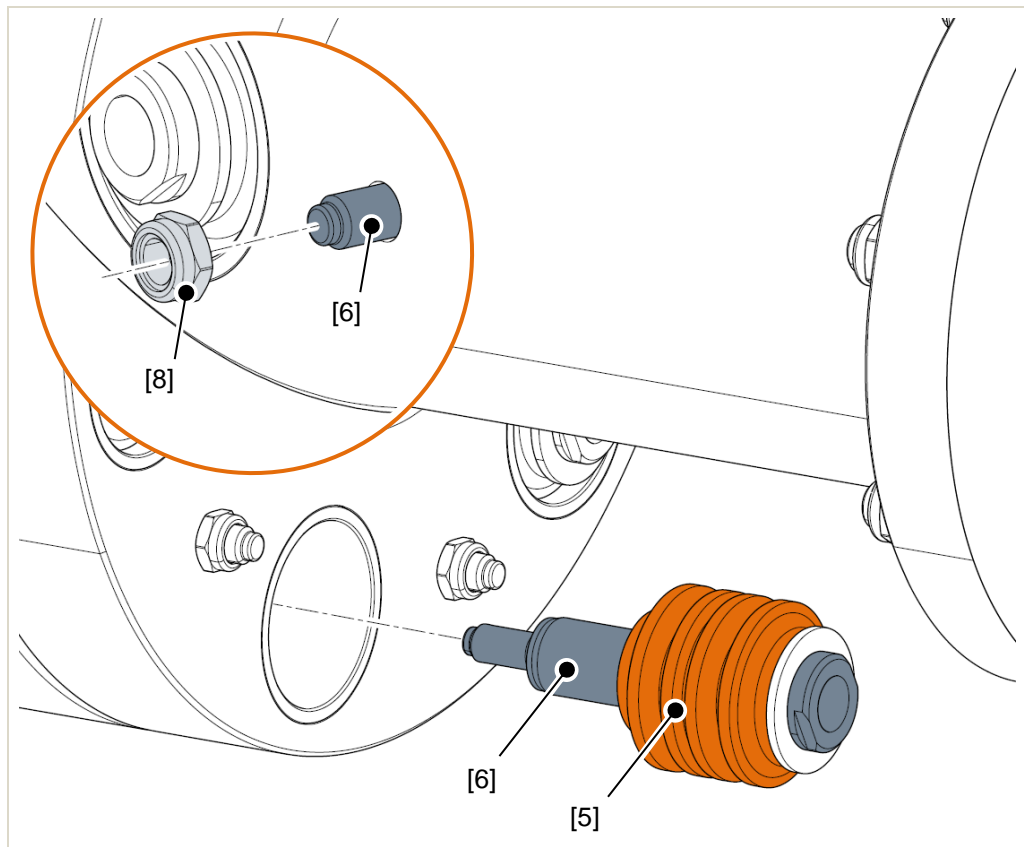

**Abb. 22 Type KWU: Replacing coupling sleeves**

- [5] Coupling sleeve  
[6] Bolt  
[8] Hexagon nut

In order to achieve uniform power transmission, the full set of coupling sleeves [5] must always be replaced.

1. Loosen and remove the hexagon nut [8].
  2. Disassemble the transmission elements. Remove the bolt [6] with the coupling sleeve [5].
  3. Pull the worn coupling sleeve off the bolt [6].
  4. Before reassembling, clean the bolts [6] and the receiving holes for the bolts [6] and sleeve holes.
  5. Replace the coupling sleeve [5].
  6. Repeat the instructions until all coupling sleeves [5] have been replaced.
- ✓ Finally, assemble the transmission elements. Follow the instructions listed in chapter → chapter 5.8.3, page 43.

## 7.4 Cleaning

### **⚠ CAUTION**

#### **Risk of chemical burns!**

There is a risk of corrosion when handling aggressive cleaning agents. Observe the manufacturer's instructions for handling cleaning agents and solvents.

- ▶ Wear appropriate protective equipment (gloves, goggles).
- ▶ Eliminate excess solvent flowing it immediately with binder.

### **ATTENTION**

#### **Damage to the coupling sleeves!**

Solvents and anti-corrosion agents may damage the coupling sleeves and change the mechanical properties of the coupling sleeve.

- ▶ Make sure that the coupling sleeves do not come into contact with solvents and anti-corrosion agents.

### **ATTENTION**

#### **Malfunctions due to penetrating dirt, metal residues and liquids!**

Penetrating dirt, metal residues and liquids may lead to malfunctions. The safe functioning of the ELCO coupling is no longer guaranteed in that case.

- ▶ Close all openings with suitable protective caps or protective devices to prevent cleaning agent from penetrating.
  - ▶ Use lint-free, firmly woven cloths to clean the ELCO coupling.
- 
- ▶ Use only detergents containing surfactants, such as Extreme Simple Green, as a cleaning agent. Observe and follow the manufacturer's instructions.
  - ▶ Do not use aggressive chemical cleaning agents. Do not use high-pressure cleaners or steam jets. Seals may be damaged and dirt and water may penetrate.
  - ▶ Never clean surfaces with sharp-edged tools.
  - ▶ Remove anti-corrosion agents and grease residues with white spirit or petroleum. Remove all deposits of liquid screw lock or sealant from all screws and threads.
  - ▶ Always perform a visual and functional check after cleaning. Carefully inspect all part grooves and working surfaces. They must be in perfect condition.



Store and dispose of leaked and used operating and auxiliary materials in accordance with the statutory provisions.

If in doubt, contact the relevant material manufacturer or material supplier for information on the type of storage and disposal.

## 8 Disposal

### 8.1 Disposal of operating materials

- ▶ Collect liquid waste in approved containers and ready the containers for proper disposal.
- ▶ Absorb spilled or leaked liquids or soak up these liquids immediately.
- ▶ When handling lubricants, make sure that no lubricants seep into the ground. Waste oil, used grease and oily or greasy cleaning rags must be disposed of in an environmentally friendly manner.
- ▶ Dispose of operating materials, in particular lubricants and greases, in accordance with the national regulations of your country and the applicable safety data sheets.
- ▶ If in doubt, check with local municipal authorities or specialised disposal companies about environmentally friendly disposal.

### 8.2 Disposal of components

Metallic materials are generally considered fully recyclable. Dispose of the components of the ELCO coupling in accordance with the country-specific waste treatment and disposal regulations. Separate the components into the following categories for recycling:

- Steel and iron
- Aluminium
- Insulating materials
- Cabling and wiring
- Electronic waste

Coupling sleeves V

The **coupling sleeves V** must be disposed of as hazardous waste. Dispose of the contents in accordance with local/regional/national/international regulations. Do not mix with other types of waste. The coupling has been entered in the SCIP database → UUID: e0935611-fa79-4424-b610-260070d265f0.

For special instructions for the disposal of the substances and materials used please refer to the table below.

Materials/ substances	Recycling	Residual waste	Hazardous waste
Metals	x	–	–
Cables	x	–	–
Seals	–	x	–
Plastics	x	(x)	–
Coupling sleeves V	–	–	x
Equipment	–	–	x
Packaging	x	–	–

## 9 Annex

### 9.1 Appendix A | Other applicable documents

Annex	Designation
A001_01	Extract from the "ELCO couplings" catalogue, RH-1008 (1201): Technical data and dimensions
A001_02	Extract from the "ELCO couplings" catalogue, RH-1008 (1201): Weights
A001_03	Extract from the "ELCO couplings" catalogue, RH-1008 (1201): Spare parts

### 9.2 Annex B | Safety data sheets

Annex	Designation
B001_01	Anticorit DFW 9301
B001_02	Tectyl 506-EH

### 9.3 Annex C | ATEX | OPTIONAL\*

Annex	Designation
C001_01	Ex003: Supplementary operating instructions for the use of ELCO couplings in potentially explosive atmospheres
C001_02	Certificate of conformity within the meaning of Directive 2014/34/EU
C001_03	Additional information: Technical data

\* These documents are sent separately with the ELCO coupling.

## Type N / W

Sizes 018 – 319 W

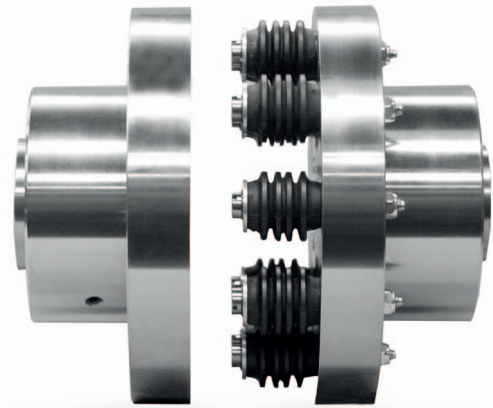

Coupling size	Coupling torque $T_{KN}$ [Nm]	Max. speeds <sup>1)</sup>		Steel Flange 1 and 2													
		I [rpm]	II [rpm]	$a_1$ [mm]	$l_1$ $l_2$ [mm]	$b_{max}^{2)}$ [mm]	$z$ [mm]	$h_1$ $h_2$ [mm]	$o$ [mm]	$p$ [mm]	$D_i^{6)}$ [mm]	$d^{6)}$	$t^{6)}$ [mm]	$x^{3)}$ [mm]	$x^{*3)}$ [mm]	$y^{4)}$ [mm]	
018 036	$18 \cdot 10^0$ $36 \cdot 10^0$	6000	—	87	30	6	—	21	30	—	40	M 6	12	28	—	28	
044 066	$44 \cdot 10^0$ $66 \cdot 10^0$	6000	—	97	35	6	—	21	30	—	50	M 8	15	25	—	25	
098 113	$98 \cdot 10^0$ $13 \cdot 10^1$	6000	—	112	40	6	—	26	36	—	60	M 8	15	30	—	30	
123 129	$23 \cdot 10^1$ $29 \cdot 10^1$	6000	—	130	50	6	—	26	36	—	70	M 8	15	20	—	20	
149 161	$49 \cdot 10^1$ $61 \cdot 10^1$	3600	5600	160	60	4	16	30	46	42	80	M 10	20	25	40	25	
184 210	$84 \cdot 10^1$ $10 \cdot 10^2$	3000	5000	190	75	4	16	30	46	42	100	M 10	20	10	25	10	
214 215	$14 \cdot 10^2$ $15 \cdot 10^2$	2650	4500	225	90	5	20	37	54	49	115	M 12	25	10	25	15	
222 228	$22 \cdot 10^2$ $28 \cdot 10^2$	2250	4000	270	100	6	20	45	63	61	125	M 12	25	20	35	20	
231 237	$31 \cdot 10^2$ $37 \cdot 10^2$	2000	3600	300	120	6	20	45	63	61	145	M 12	25	5	15	0	
247 259 W	$47 \cdot 10^2$ $59 \cdot 10^2$	1800	3300	340	140	6	25	55	74	73	170	M 16	30	5	20	0	
271 285 W	$71 \cdot 10^2$ $85 \cdot 10^2$	1650	3000	380	160	6	25	55	74	73	185	M 20	35	0	0	0	
311 314 W	$11 \cdot 10^3$ $14 \cdot 10^3$	1500	2800	440	180	7	25	68	90	92	205	M 20	35	0	10	0	
316 319 W	$16 \cdot 10^3$ $19 \cdot 10^3$	1250	2500	500	200	7	25	68	90	92	225	M 20	35	0	0	0	

1) For maximum speed II, from size 149 on only steel couplings with hollow bolts must be used.

2) Standard fitting dimension  $b_{norm} = 1/2 b_{max}$

3) Space required for driving out the transmission bolts:  $x$  = for couplings without intermediate ring,  $x^*$  = for couplings with intermediate ring.

4)  $y$  = space required for removing the compression sleeves.

5) The intermediate ring is made of steel.

6) With adjusting screw up to size 237 on request - from size 247 on adjusting screw are provided as standard.

## Type N

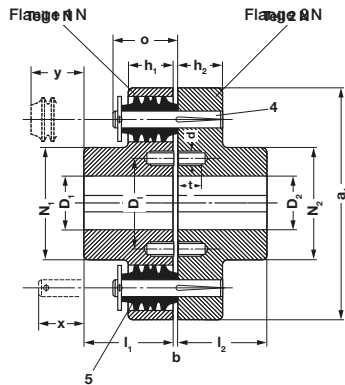

Design for sizes 018 – 129

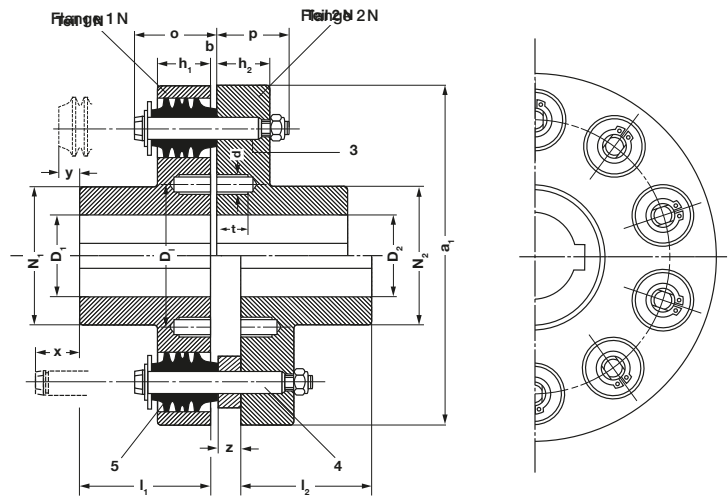

Design with intermediate ring for sizes 149 – 316

## Type W

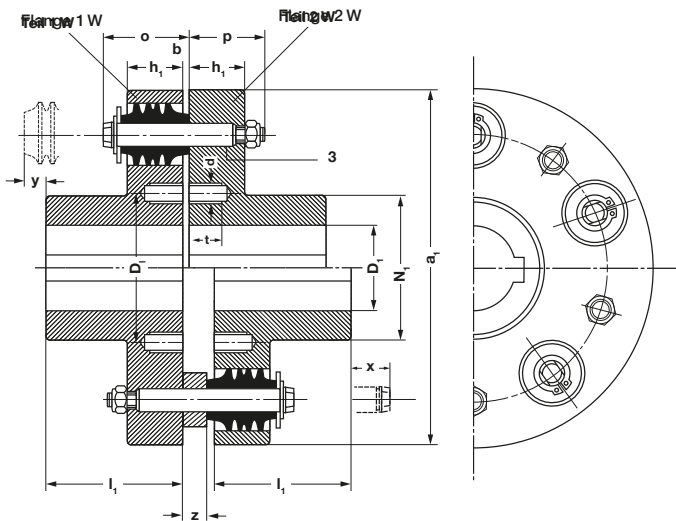

Design with intermediate ring

Coupling size	Steel					
	Flange 1 N / 1 W / 2 W			Flange 2 N		
	Hub N <sub>1</sub> [mm]	Pilot hole <sup>2)</sup> [mm]	Finished bore <sup>1)</sup> D <sub>1</sub> [mm]	Hub N <sub>2</sub> [mm]	Pilot hole <sup>2)</sup> [mm]	Finished bore <sup>1)</sup> D <sub>2</sub> [mm]
018	35	9	10–20	40	9	10–25
036						
044	45	11	12–28	50	11	12–30
066						
098	52	15	16–32	63	15	16–40
113						
123	68	18	19–45	80	18	19–52
129						
149	82	18	19–55	82	18	19–55
161						
184	110	23	24–75	110	23	24–75
210						
214	125	29	30–85	135	29	30–90
215						
222	150	34	35–100	150	34	35–100
228						
231	180	39	40–120	180	39	40–120
237						
247	180	44	45–120	200	44	45–135
259 W						
271	220	53	55–145	220	53	55–145
285 W						
311	250	63	65–165	250	63	65–165
314 W						
316	280	73	75–185	280	73	75–185
319 W						

### Information for engineers

The ELCO-Coupling can be extended in axial direction. As of size 149, radial dismounting of the coupled shafts is possible without axial shifting after dismounting the bolts.

For greater shaft distances, the ELCO-Coupling can be equipped with intermediate rings. For max. admissible shaft distances please see the chart on page 10.

Speed	Material	Intermediate ring <sup>3)</sup>	Bolts
I	steel	without / with	solid
II	steel	with	hollow

Bore of hub chamfered: sizes 018 - 129 = 1 x 45°,  
 sizes 149 - 259 W = 1,5 x 45°, sizes 271 - 319 W = 2 x 45°

1) The couplings are normally bored to DIN ISO 286-2 using ISO tolerances "K 7" or "H 7".  
 Recommended fit is: h 6 / K 7 or m 6 / H 7 or k 6 / H 7.  
 Sizes 018–210 will always be supplied with adjusting screw when ready bored and keywayed.

2) Pilot holes have no fit tolerance. Parallel keys and taper keys are supplied on request, at extra charge.

With high shock-loads or reduced hubs respectively, the load on the key must be checked.

3) Sizes and dimensions of ELCO-Couplings made of cast iron upon request

## Type N / W

### Sizes 324 – 454

Coupling size	Coupling torque $T_{KN}$ [Nm]	Max. speeds <sup>1)</sup>		Steel Flange 1 and 2													
		I [rpm]	II [rpm]	$a_1$ [mm]	$l_1$ $l_2$ [mm]	$b_{max}^{2)}$ [mm]	$z$ [mm]	$h_1$ [mm]	$h_2$ [mm]	$f$ [mm]	$o$ [mm]	$p$ [mm]	$D_f$ [mm]	$d$	$t$ [mm]	$x, x^{*3)}$ [mm]	$y^{4)}$ [mm]
324 329 W <sup>3)</sup>	24 · 10 <sup>3</sup> 29 · 10 <sup>3</sup>	1120	2250	560	220	8	30	83	76 —	46	106	107	240/280 240	M 20	35	0	0
335 341 W <sup>3)</sup>	35 · 10 <sup>3</sup> 41 · 10 <sup>3</sup>	1000	2000	640	250	8	30	83	76 —	46	106	107	280 260	M 20	35	0	0
353	53 · 10 <sup>3</sup>	850	1750	750	280	9	30	102	93	58	127	128	300	M 24	42	0	0
378	78 · 10 <sup>3</sup>	750	1500	880	320	9	—	102	93	58	127	128	210 250 290 330	M 24	42	0	0
412	12 · 10 <sup>4</sup>	630	1300	960	350	10	—	128	115	60	158	159	240 280 320 380	M 30	55	0	0
416	16 · 10 <sup>4</sup>	630	1300	1040	375	10	—	128	115	60	158	159	240 280 320 380	M 30	55	0	0
420	20 · 10 <sup>4</sup>	560	1200	1160	400	10	—	128	115	60	158	159	260 310 360 420	M 36	65	0	0
426	26 · 10 <sup>4</sup>	500	1050	1210	425	12	—	160	148	75	195	200	310 360 410 440 480	M 36	65	0	0
432	32 · 10 <sup>4</sup>	500	1050	1285	450	12	—	160	148	75	195	200	320 400 470 510 570	M 42	75	0	0
443	43 · 10 <sup>4</sup>	450	890	1430	500	12	—	160	148	75	195	200	330 410 490 530 590	M 42	70	0	0
454	54 · 10 <sup>4</sup>	400	750	1580	560	12	—	160	148	75	195	200	370 440 510 580 650	M 48	80	0	0

3) ELCO-Couplings type W only available in steel  
Couplings for torque higher than  $T_{KN} = 54 \cdot 10^4$  Nm are available upon request.

Observe the footnotes on pages 10 and 11.

## Type N

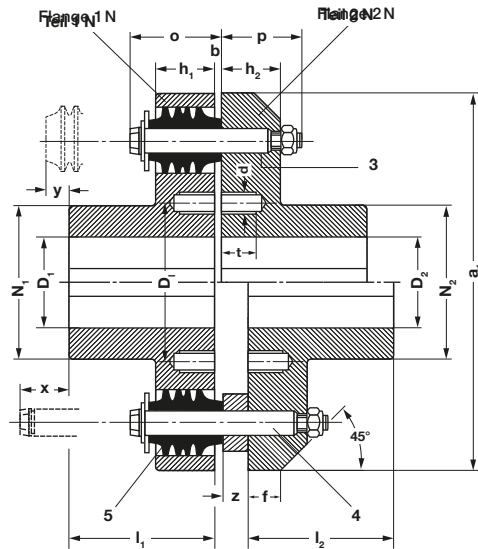

Design with intermediate ring for sizes 324–454

Bore of hub chamfered: sizes 324–353 = 2 x 45°, sizes 378–454 = 3 x 45°

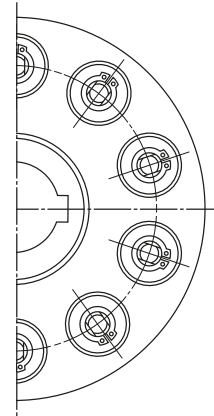

Coupling size	Steel					
	Flange 1 N / 1 W / 2 W			Flange 2 N		
	Hub N <sub>1</sub> [mm]	Pilot hole <sup>2)</sup> [mm]	Finished bore <sup>1)</sup> D <sub>1</sub> [mm]	Hub N <sub>2</sub> [mm]	Pilot hole <sup>2)</sup> [mm]	Finished bore <sup>1)</sup> D <sub>2</sub> [mm]
324	290	on request	95–190	335	on request	95–220
329 W	275	on request	85–180	—	on request	—
335	335	on request	110–220	365	on request	110–240
341 W	305	on request	95–200	—	on request	—
353	365	on request	140–240	380	on request	140–250
378	245	on request	125–160	245	on request	125–160
	305		> 160–200	305		> 160–200
	365		> 200–240	365		> 200–240
	380		> 240–250	425		> 240–280
412	275	on request	140–180	275	on request	140–180
	335		> 180–220	335		> 180–220
	395		> 220–260	395		> 220–260
	425		> 260–280	485		> 260–320
416	275	on request	140–180	275	on request	140–180
	335		> 180–220	335		> 180–220
	395		> 220–260	395		> 220–260
	450		> 260–300	485		> 260–320
420	305	on request	160–200	305	on request	160–200
	380		> 200–250	380		> 200–250
	450		> 250–300	450		> 250–300
	485		> 300–320	545		> 300–360
426	350	on request	180–230	350	on request	180–230
	425		> 230–280	425		> 230–280
	500		> 280–330	500		> 280–330
	545		> 330–360	545		> 330–360
	605		> 360–400	605		> 360–400
432	360	on request	190–240	360	on request	190–240
	450		> 240–300	450		> 240–300
	530		> 300–350	530		> 300–350
	570		> 350–380	570		> 350–380
	640		> 380–425	640		> 380–425
443	380	on request	200–250	380	on request	200–250
	470		> 250–310	470		> 250–310
	560		> 310–370	560		> 310–370
	605		> 370–400	605		> 370–400
	680		> 400–450	680		> 400–450
454	410	on request	220–270	410	on request	220–270
	500		> 270–330	500		> 270–330
	590		> 330–390	590		> 330–390
	680		> 390–450	680		> 390–450
	760		> 450–500	760		> 450–500

2) If not otherwise expressly specified, we supply coupling halves with a pilot hole 5 mm smaller in diameter than the desired finished bore size.

### With enquiries or when ordering please state:

1. Type of coupling
2. Bore D in mm and tolerances for both flanges
3. Connection of shaft/hub
4. Kind of driving and driven machine
5. Maximum power to be transmitted, starting torque and magnitude of shock loads
6. Moments of inertia of driving and driven machine
7. Speed in rpm
8. Type of compression sleeves (U, V, W)
9. Ambient temperature
10. Frequency of engagements/disengagements

### Information for engineers

The ELCO-Coupling can be extended in axial direction. As of size 149, radial dismounting of the coupled shafts is possible without axial shifting after dismounting the bolts.

For greater shaft distances, the ELCO-Coupling can be equipped with intermediate ring spacers. For max. admissible shaft distances please see the chart on page 12.

Speed	Material	Intermediate ring <sup>3)</sup>	Bolts
I	steel	without / with	solid
II	steel	with	hollow

## Weights [kg]

Values refer to nominal diameter of the bores and the hub diameter, corresponding to the bores.

All values refer to steel as material of the couplings.

Flange 2: - including transmission components.

Type W: - flange 1 and flange 2 including their transmission components.

Coupling size	Nom. dia. [mm]	For all Types		Type N/W		Type B		Intermediate ring
		Flange 1	Flange 2	Flange 1 + 2	Flange 2/12	Flange 1 + 2/12		
018	10	0,93	1,1	2,03	—	—	—	
036		0,85	1,15	2,0	—	—	—	
044		1,1	1,5	2,6	—	—	—	
066	20	1,0	1,55	2,55	—	—	—	
098		1,4	2,8	4,2	—	—	—	
113		1,2	2,9	4,1	—	—	—	
123	30	2,1	3,6	5,7	—	—	—	
129		1,9	3,7	5,6	—	—	—	
149		3,6	5,9	9,5	10,2	13,8	0,4	
161	50	3,2	6,0	9,2	—	—	0,5	
184		6,5	9,5	16	15	21,5	0,5	
210		6,1	9,6	15,7	—	—	0,6	
214	60	10	15,5	25,5	25,8	35,8	0,7	
215		9,9	15,5	25,4	—	—	0,8	
222		18,5	26,0	44,5	44	63	1,0	
228	80	17	26,5	43,5	—	—	1,3	
231		27	37	64	55	82	1,3	
237		26	37	63	—	—	1,6	
247	90	37	55	91	83	120	2,1	
259 W		43	43	88	—	—	2,6	
271		55	73	128	108	163	2,6	
285 W	110	63	63	126	—	—	3,1	
311		87	116	203	170	257	3,5	
314 W		100	100	200	—	—	4,4	
316	120	118	154	272	236	354	4,4	
319 W		134	134	268	—	—	5,3	
324		146	224	370	350	496	7,4	
329 W	160	169	169	338	—	—	8,9	
335		215	300	515	470	685	8,9	
341 W		232	232	464	—	—	10,4	
353	180	346	455	807	660	1006	10,4	
378		397	518	915	—	—	—	
412		545	780	1325	—	—	—	
416	200	550	810	1360	—	—	—	
420		780	1050	1830	—	—	—	
426		1050	1460	2510	—	—	—	
432	240	1160	1660	2820	—	—	—	
443		1500	2060	3560	—	—	—	
454		2340	3150	5490	—	—	—	

For designs with an intermediate ring, the coupling weights are to be increased by the weight of the intermediate ring which is listed separately.

In case of separate calculation, the weight of the intermediate ring is to be added to that of flange 2 or flange 2/12

The weight of the intermediate ring refers to one set.

Type S		
Brake drum Flange 12 Ø [mm]	Width [mm]	[kg]
200	75	5,0
250	95	8,25
315	118	14,6
400	150	28,6
500	190	51
630	236	93
710	265	124
800	300	169

The weights of the coupling are the same as those of type N.

By adding the weights of the brake drum and of flange 2 of the ELCO-Coupling type N you obtain the weight of flange 2/12.

## Spare Parts

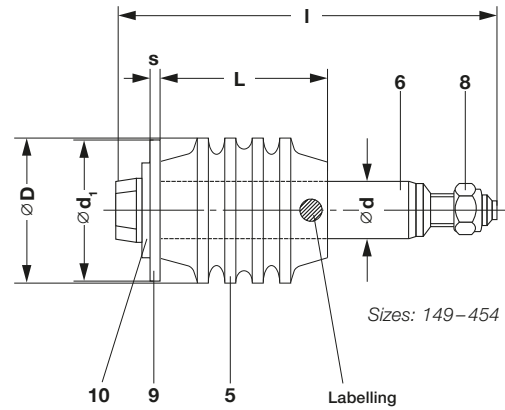
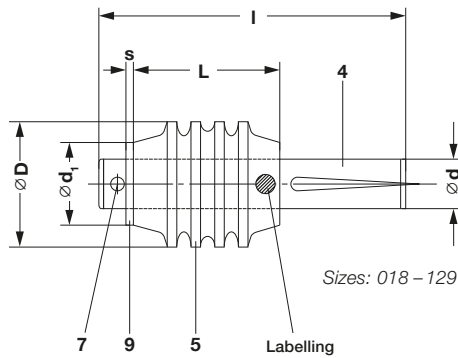

Size	Qts.	5 Sleeves		4 or 6 Transmitting pin				9 Washer		10 Circlip	7 Grooved pin	8 Nut
		D	L <sup>3)</sup>	d	l	l <sup>1)</sup>	l <sup>2)</sup>	d <sub>1</sub>	s			
018	2											
036	4											
044	4	19,6	25	8	51	—	—	13	1,5	—	Ø 2,5 x 12	—
066	6											
098	6											
113	8	24,6	30	10	62	62	—	16	1,5	—	Ø 3 x 16	—
123	8											
129	10											
149	8											
161	10	31,4	36,5	12,8	88	102	104	24	2	13 x 1	—	M 8
184	10											
210	12											
214	10	39,2	44,5	15,8	103,5	117,5	123,5	28	2,5	16 x 1	—	M 8
215	11											
222	8											
228	10	49,1	52,5	19,8	123,5	139	143,5	38	3	20 x 1,2	—	M 10
231	10											
237	12											
247	8					165						
259 W	10	62,1	62,5	24,8	147	165	172	48	3	25 x 1,2	—	M 12
271	10					—						
285 W	12					—						
311	8					200,5						
314 W	10	79	77,2	32,8	181,5	200,5	206,5	62	4	33 x 1,5	—	M 16
316	10					—						
319 W	12					—						
324	10					235						
329 W	12	98,7	93	40	213	235	243	76	4	40 x 1,75	—	M 20
335	12					—						
341 W	14					—						
353	10	123,5	113,5	50	255	—	285	92	4	50 x 2	—	M 24
378	14											
412	12											
416	14	158,3	141,5	63	316,5	—	—	140	6	62 x 2	—	M 30
420	16											
426	12											
432	14	198	176,5	80	395	—	—	175	6	80 x 2,5	—	M 36
443	16											
454	18											



### Sleeve quality

### Labelling

<b>U</b>	old = white / new = <b>U</b>
<b>W</b>	old = yellow / new = <b>W</b>
<b>V</b>	old = purple / new = <b>V</b>

Information on sleeve quality see page 4 + 5

1) Execution S 2) For execution with intermediate ring 3) Normal length (without preload)

## SAFETY DATA SHEET

According to Regulation (EC) No. 1907/2006 (REACH) Article 31, Annex II as amended.

### SECTION 1: Identification of the substance/mixture and of the company/undertaking

#### 1.1 Product identifier

**Product name:** ANTICORIT DFW 9301

#### 1.2 Relevant identified uses of the substance or mixture and uses advised against

**Identified uses:** Anticorrosion product

**Uses advised against:** No uses advised against identified.

#### 1.3 Details of the supplier of the safety data sheet

##### Manufacturer / Supplier

Fuchs Schmierstoffe GmbH  
Friesenheimer Str. 19  
68169 Mannheim

Telephone:

+49 621 3701-0 (ZENTRALE)

Fax:

+49 621 3701-570

##### Contact Person:

Fuchs Schmierstoffe GmbH Abteilung Produktsicherheit

Telephone:

+49 621 3701-1333

Fax:

+49 621 3701-7303

E-mail:

produktsicherheit-FS@fuchs.com

#### 1.4 Emergency telephone number:

+49 621 3701-1333 / +49 621 3701-0 (Mo-Do 8-17, Fr 8-16)

### SECTION 2: Hazards identification

#### 2.1 Classification of the substance or mixture

The product has been classified and labelled as hazardous according to regulation (EU) 1272/2008 (CLP).

**Classification according to Regulation (EC) No 1272/2008 as amended.**

##### Health Hazards

Aspiration Hazard

Category 1

H304: May be fatal if swallowed and enters airways.

##### Hazard summary

##### Physical Hazards:

Can form flammable vapour-air mixtures during the application.

##### Health Hazards

##### Ingestion:

If ingested, material may be aspirated into the lungs and cause chemical pneumonitis. Treat appropriately.

#### 2.2 Label Elements

**Product name:** ANTICORIT DFW 9301

**Contains:** Hydrocarbons, low viscosity



**Signal Words:** Danger

**Hazard Statement(s):** H304: May be fatal if swallowed and enters airways.

**Precautionary Statements**

**Response:** P301+P310: IF SWALLOWED: Immediately call a POISON CENTER/doctor.  
P331: Do NOT induce vomiting.

**Disposal:** P501: Dispose of contents/container to an appropriate treatment and disposal facility in accordance with applicable laws and regulations, and product characteristics at time of disposal.

**Supplemental label information**

EUH208: Contains: Calcium Sulfonate, Ca sulfonate. May produce an allergic reaction.

**2.3 Other hazards:** By handling of mineral oil products and chemical products no particular hazard is known when normal precautions (item 7) and personal protective equipment (item 8) are kept. The product may not be released into the environment without control.

**SECTION 3: Composition/information on ingredients**

**3.2 Mixtures**

**General information:** Mixture based on severely refined mineral base oils with corrosion preventive agents and volatile hydrocarbons.

Chemical name	Identifier	Concentration *	REACH Registration No.	Notes
Hydrocarbons, low viscosity	EINECS: 926-141-6	50,00 - 100,00%	01-2119456620-43	
Calcium Sulfonate	EINECS: 263-093-9	1,00 - 5,00%	01-2119488992-18	
Glycol derivative	EINECS: 203-961-6	1,00 - 5,00%	01-2119475104-44	
Ca sulfonate	EINECS: 939-603-7	1,00 - 5,00%	01-2119978241-36	
phenolic antioxidant	EINECS: 204-881-4	0,10 - 1,00%	01-2119565113-46	

\* All concentrations are percent by weight unless ingredient is a gas. Gas concentrations are in percent by volume.

PBT: persistent, bioaccumulative and toxic substance.

vPvB: very persistent and very bioaccumulative substance.

**Product name:** ANTICORIT DFW 9301

### Classification

Chemical name	Identifier	Classification
Hydrocarbons, low viscosity	EINECS: 926-141-6	CLP: Asp. Tox. 1;H304
Calcium Sulfonate	EINECS: 263-093-9	CLP: Skin Sens. 1B;H317
Glycol derivative	EINECS: 203-961-6	CLP: Eye Irrit. 2;H319
Ca sulfonate	EINECS: 939-603-7	CLP: Skin Sens. 1B;H317
phenolic antioxidant	EINECS: 204-881-4	CLP: Aquatic Acute 1;H400, Aquatic Chronic 1;H410

CLP: Regulation No. 1272/2008.

For the wording of the listed hazard statements refer to section 16.

Please note that the mineral oils and petroleum distillates used in our products are severely refined and have a DMSO extract < 3% as measured by method IP 346 and are not classified as carcinogenic according to Note L of Annex VI of Regulation EC 1272/2008."

### SECTION 4: First aid measures

**General:** Instantly remove any clothing soiled by the product.

#### 4.1 Description of first aid measures

**Inhalation:** Supply fresh air; consult doctor in case of symptoms.

**Eye contact:** Promptly wash eyes with plenty of water while lifting the eye lids.

**Skin Contact:** Wash with water and soap; pay attention: skin degreasing product.

**Ingestion:** Call a physician or poison control center immediately. Rinse mouth. Never give liquid to an unconscious person. If vomiting occurs, keep head low so that stomach content doesn't get into the lungs. Do NOT induce vomiting.

**4.2 Most important symptoms and effects, both acute and delayed:** If ingested, material may be aspirated into the lungs and cause chemical pneumonitis. Treat appropriately. Headache.

**4.3 Indication of any immediate medical attention and special treatment needed** Get medical attention if symptoms occur.

### SECTION 5: Firefighting measures

**General Fire Hazards:** Use water spray to keep fire-exposed containers cool.

#### 5.1 Extinguishing media

**Suitable extinguishing media:** CO<sub>2</sub>, fire extinguishing powder or fog like water spraying. Extinguish larger fires with alcohol resistant foam or spray water with suitable surfactant added

**Unsuitable extinguishing media:** Water with a full water jet.

**Product name:** ANTICORIT DFW 9301

<b>5.2 Special hazards arising from the substance or mixture:</b>	Can form explosive vapor-air mixtures at higher temperatures.
<b>5.3 Advice for firefighters</b>	
<b>Special fire fighting procedures:</b>	Move container from fire area if it can be done without risk. Dispose of fire debris and contaminated fire fighting water in accordance with official regulations. Collect contaminated fire fighting water separately. It must not enter drains.
<b>Special protective equipment for fire-fighters:</b>	Self-contained breathing apparatus and full protective clothing must be worn in case of fire.

#### SECTION 6: Accidental release measures

<b>6.1 Personal precautions, protective equipment and emergency procedures:</b>	In case of spills, beware of slippery floors and surfaces. Keep away from sources of ignition - No smoking.
<b>6.2 Environmental Precautions:</b>	Prevent from spreading (e.g. by binding or oil barriers). Avoid release to the environment. Environmental manager must be informed of all major spillages. Prevent further leakage or spillage if safe to do so. Do not allow to enter drainage system, surface or ground water.
<b>6.3 Methods and material for containment and cleaning up:</b>	Absorb with liquid-binding material (sand, diatomite, acidbinders, universal binders, sawdust). Dispose of the material collected according to regulations. Stop the flow of material, if this is without risk.
<b>6.4 Reference to other sections:</b>	See Section 8 of the SDS for Personal Protective Equipment. See Section 7 for information on safe handling See Section 13 for information on disposal.

#### SECTION 7: Handling and storage:

<b>7.1 Precautions for safe handling:</b>	Use only in well-ventilated areas. Risk of vapor concentration on the floor and in low-lying areas. Prevent formation of aerosols. Do not eat, drink or smoke when working with the product. Take usual precautions when handling mineral oil products or chemical products. Observe good industrial hygiene practices. Provide adequate ventilation.
<b>7.2 Conditions for safe storage, including any incompatibilities:</b>	Store locked up. Local regulations concerning handling and storage of waterpolluting products have to be followed. The precautions for storing and handling of flammable liquids have to be kept. Local regulations for common storage of flammable liquids have to be followed. Do not heat up to temperatures close to the flash point.
<b>7.3 Specific end use(s):</b>	Not applicable
<b>Storage Class:</b>	10, Combustible liquids

**Product name:** ANTICORIT DFW 9301

**SECTION 8: Exposure controls/personal protection**

**8.1 Control Parameters**

**Occupational Exposure Limits**

Chemical name	Type	Exposure Limit Values	Source
Hydrocarbons, low viscosity	AGW	300 mg/m <sup>3</sup>	Germany. TRGS 900, Occupational Exposure Limits (AGW)
Glycol derivative - Vapor and aerosol.	AGW	10 ppm 67 mg/m <sup>3</sup>	Germany. TRGS 900, Occupational Exposure Limits (AGW) (04 2014)

**8.2 Exposure controls**

**Appropriate engineering controls:**

Provide adequate ventilation. Ventilation rates should be matched to conditions. If applicable, use process enclosures, local exhaust ventilation, or other engineering controls to maintain airborne levels below recommended exposure limits. If exposure limits have not been established, maintain airborne levels to an acceptable level.

**Individual protection measures, such as personal protective equipment**

**General information:**

Wash hands before breaks and after work. Use personal protective equipment as required. Personal protection equipment should be chosen according to the CEN standards and in discussion with the supplier of the personal protective equipment. The usual precautionary measures should be adhered to in handling the chemicals or the mineral oil products.

**Eye/face protection:**

Safety glasses (EN 166) recommended during refilling.

**Skin protection**

**Hand Protection:**

Material: Nitrile-butadiene rubber (NBR).  
Min. Breakthrough time:  $\geq 480$  min  
Recommended thickness of the material:  $\geq 0,38$  mm

Avoid long-term and repeated skin contact. Suitable gloves can be recommended by the glove supplier. Use skin protection cream for preventive skin protection. Protective gloves, where permitted in acc. to safety directions. The exact break through time has to be found out by the manufacturer of the protective gloves and has to be observed.

**Other:**

Do not carry cleaning cloths impregnated with the product in trouser pockets. Wear suitable protective clothing.

**Respiratory Protection:**

Ensure good ventilation/exhaustion at the workplace. Avoid breathing vapour/ aerosol.

**Thermal hazards:**

Not known.

**Hygiene measures:**

Always observe good personal hygiene measures, such as washing after handling the material and before eating, drinking, and/or smoking. Routinely wash work clothing to remove contaminants. Discard contaminated footwear that cannot be cleaned.

**Environmental Controls:**

No data available.

**Product name:** ANTICORIT DFW 9301

## SECTION 9: Physical and chemical properties

### 9.1 Information on basic physical and chemical properties

#### Appearance

<b>Physical state:</b>	liquid
<b>Form:</b>	liquid
<b>Color:</b>	Brown
<b>Odor:</b>	Characteristic
<b>Odor Threshold:</b>	Not applicable for mixtures
<b>pH:</b>	Not applicable
<b>Freezing point:</b>	Not applicable for mixtures
<b>Boiling Point:</b>	Value not relevant for classification
<b>Flash Point:</b>	92 °C
<b>Evaporation Rate:</b>	Not applicable for mixtures
<b>Flammability (solid, gas):</b>	Value not relevant for classification
<b>Flammability Limit - Upper (%)-:</b>	Value not relevant for classification
<b>Flammability Limit - Lower (%)-:</b>	Value not relevant for classification
<b>Vapor pressure:</b>	Not applicable for mixtures
<b>Vapor density (air=1):</b>	Not applicable for mixtures
<b>Density:</b>	0,83 g/ml (15,00 °C)
<b>Solubility(ies)</b>	
<b>Solubility in Water:</b>	Insoluble in water
<b>Solubility (other):</b>	No data available.
<b>Partition coefficient (n-octanol/water):</b>	Not applicable for mixtures
<b>Autoignition Temperature:</b>	Value not relevant for classification
<b>Decomposition Temperature:</b>	Value not relevant for classification
<b>Kinematic viscosity:</b>	6,7 mm <sup>2</sup> /s (20,00 °C)
<b>Explosive properties:</b>	Value not relevant for classification
<b>Oxidizing properties:</b>	Value not relevant for classification
<b>9.2 Other information</b>	No data available.

## SECTION 10: Stability and reactivity

<b>10.1 Reactivity:</b>	Stable under normal use conditions.
<b>10.2 Chemical Stability:</b>	Stable under normal use conditions.
<b>10.3 Possibility of hazardous reactions:</b>	Stable under normal use conditions.
<b>10.4 Conditions to avoid:</b>	Stable under normal use conditions.
<b>10.5 Incompatible Materials:</b>	Strong oxidizing substances. Strong acids. Strong bases.
<b>10.6 Hazardous Decomposition Products:</b>	Thermal decomposition or combustion may liberate carbon oxides and other toxic gases or vapors.

**Product name:** ANTICORIT DFW 9301

**SECTION 11: Toxicological information**

**11.1 Information on toxicological effects**

**Acute toxicity**

**Oral**

**Product:**

Not classified for acute toxicity based on available data.

**Specified substance(s)**

Hydrocarbons, low viscosity

LD 50 (Rat): > 5.000 mg/kg (OECD 401)

Calcium Sulfonate

LD 50 (Rat): > 16.000 mg/kg

Glycol derivative

LD 50 (Rat): 3.384 mg/kg

phenolic antioxidant

LD 50 (Rat): 2.930 mg/kg (OECD 401)

**Dermal**

**Product:**

Not classified for acute toxicity based on available data.

**Specified substance(s)**

Hydrocarbons, low viscosity

LD 50 (Rabbit): > 5.000 mg/kg (OECD 402)

Glycol derivative

LD 50 (Rabbit): 2.700 mg/kg

phenolic antioxidant

LD 50 (Rat): > 5.000 mg/kg (OECD 402)

**Inhalation**

**Product:**

Not classified for acute toxicity based on available data.

**Skin Corrosion/Irritation:**

**Product:**

Based on available data, the classification criteria are not met.

**Specified substance(s)**

Hydrocarbons, low viscosity

OECD 404

Not irritant.

Calcium Sulfonate

OECD 404 (Rabbit):

Not irritant.

**Serious Eye Damage/Eye Irritation:**

**Product:**

Based on available data, the classification criteria are not met.

**Specified substance(s)**

Calcium Sulfonate

OECD 405 (Rabbit):

Not irritant.

**Product name:** ANTICORIT DFW 9301

**Respiratory or Skin Sensitization:**

**Product:**

Experimental data has shown that the concentration of potentially sensitizing components present in this product does not induce skin sensitization.

**Specified substance(s)**

Hydrocarbons, low viscosity

No sensitizing effect (guinea pig); OECD 406

phenolic antioxidant

No sensitizing effect (guinea pig); OECD 406

**Germ Cell Mutagenicity**

**Product:**

Based on available data, the classification criteria are not met.

**Carcinogenicity**

**Product:**

Based on available data, the classification criteria are not met.

**Reproductive toxicity**

**Product:**

Based on available data, the classification criteria are not met.

**Specific Target Organ Toxicity - Single Exposure**

**Product:**

Based on available data, the classification criteria are not met.

**Specific Target Organ Toxicity - Repeated Exposure**

**Product:**

Based on available data, the classification criteria are not met.

**Aspiration Hazard**

**Product:**

May be fatal if swallowed and enters airways.

**Other adverse effects:**

No data available.

**SECTION 12: Ecological information**

**12.1 Toxicity**

**Acute toxicity**

**Product:**

Based on available data, the classification criteria are not met.

**Fish**

**Specified substance(s)**

Hydrocarbons, low viscosity

LC 50 (Fish, 96 h): 1.000 mg/l (OECD 203)

Calcium Sulfonate

LC 50 (Fish, 96 h): > 10.000 mg/l (OECD 203)

Glycol derivative

LC 50 (Fish, 96 h): 1.300 mg/l

Ca sulfonate

LC 50 (Fish, 96 h): > 101 mg/l

**Aquatic Invertebrates**

**Specified substance(s)**

Calcium Sulfonate

EC 50 (Water flea (Simocephalus vetulus), 48 h): > 100 mg/l (OECD 202)

**Product name:** ANTICORIT DFW 9301

---

Glycol derivative EC 50 (Water Flea, 48 h): > 101 mg/l

Ca sulfonate EC 50 (Water Flea, 48 h): > 1.001 mg/l

**Chronic ToxicityProduct:** Based on available data, the classification criteria are not met.

**Aquatic Invertebrates**

**Specified substance(s)**

phenolic antioxidant NOEC (Water Flea, 21 d): > 0,39 mg/l

**Toxicity to Aquatic Plants**

**Specified substance(s)**

Hydrocarbons, low viscosity EC 50 (Alga, 72 h): > 1.000 mg/l (OECD 201)

Glycol derivative EC 50 (Alga, 96 h): > 101 mg/l

Ca sulfonate EC 50 (Alga, 72 h): > 101 mg/l

**12.2 Persistence and Degradability**

**Biodegradation**

**Product:** Not applicable for mixtures

**Specified substance(s)**

Hydrocarbons, low viscosity (OECD 301F) Readily biodegradable

Calcium Sulfonate 8,6 % (28 d) Not easily biodegradable

phenolic antioxidant 30 % (OECD 302C)

**12.3 Bioaccumulative potential**

**Product:** Not applicable for mixtures

**Specified substance(s)**

phenolic antioxidant May be accumulated in organism

**12.4 Mobility in soil:**

**Product:** Not applicable for mixtures

**12.5 Results of PBT and vPvB assessment:**

The product does not contain any substances fulfilling the PBT/vPvB criteria.

**12.6 Other adverse effects:**

No data available.

**Water Hazard Class (WGK):**

WGK 1: slightly water-endangering.

Product name: ANTICORIT DFW 9301

## SECTION 13: Disposal considerations

### 13.1 Waste treatment methods

**General information:** Dispose in accordance with all applicable regulations.

**Disposal methods:** Discharge, treatment, or disposal may be subject to national, state, or local laws.

#### European Waste Codes

07 04 04\*: other organic solvents, washing liquids and mother liquors

## SECTION 14: Transport information

### ADR/RID

14.1 UN Number: —  
 14.2 UN Proper Shipping Name: —  
 14.3 Transport Hazard Class(es)  
   Class: Non-dangerous goods  
   Label(s): —  
   Hazard No. (ADR): —  
   Tunnel restriction code: —  
 14.4 Packing Group: —  
 14.5 Environmental hazards: —  
 14.6 Special precautions for user: —

### ADN

14.1 UN Number: —  
 14.2 UN Proper Shipping Name: —  
 14.3 Transport Hazard Class(es)  
   Class: Non-dangerous goods  
   Label(s): —  
 14.3 Packing Group: —  
 14.5 Environmental hazards: —  
 14.6 Special precautions for user: —

### IMDG

14.1 UN Number: —  
 14.2 UN Proper Shipping Name: —  
 14.3 Transport Hazard Class(es)  
   Class: Non-dangerous goods  
   Label(s): —  
   EmS No.: —  
 14.3 Packing Group: —  
 14.5 Environmental hazards: —  
 14.6 Special precautions for user: —

**Product name:** ANTICORIT DFW 9301

**IATA**

- 14.1 UN Number: –
- 14.2 Proper Shipping Name: –
- 14.3 Transport Hazard Class(es):  
Class: Non-dangerous goods  
Label(s): –
- 14.4 Packing Group: –
- 14.5 Environmental hazards: –
- 14.6 Special precautions for user: –

**14.7 Transport in bulk according to Annex II of MARPOL and the IBC Code:** Not applicable.

**SECTION 15: Regulatory information**

**15.1 Safety, health and environmental regulations/legislation specific for the substance or mixture:**

**EU Regulations**

**Regulation (EC) No. 2037/2000 Substances that deplete the ozone layer:** none

**Regulation (EC) No. 850/2004 on persistent organic pollutants:** none

**National Regulations**

**Water Hazard Class (WGK):** WGK 1: slightly water-endangering.

**15.2 Chemical safety assessment:** No Chemical Safety Assessment has been carried out.

**SECTION 16: Other information**

**Revision Information:** Vertical lines in the margin indicate an amendment.

**Wording of the H-statements in section 2 and 3**

- H304 May be fatal if swallowed and enters airways.
- H317 May cause an allergic skin reaction.
- H319 Causes serious eye irritation.
- H400 Very toxic to aquatic life.
- H410 Very toxic to aquatic life with long lasting effects.

**Other information:** The classification complies with the current EU lists; however, it has been supplemented with expert literature information and information provided by/about our company. It was derived from the test data and/or the application of the conventional method.

**Revision Date:** 10.04.2019

**Product name:** ANTICORIT DFW 9301

---

**Disclaimer:**

The data contained in this safety data sheet are based on our current knowledge and experience and are given to the best of our knowledge and belief. It characterizes the product only with regard to safety requirements for handling, transport and disposal. The data do not describe the product's properties (tech. product specification). Neither should any agreed property nor the suitability of the product for any specific technical application be deduced from the data contained in this safety data sheet. Modifications on this document are not allowed. The data are not transferable to other products. In the case of mixing the product with other products or in the case of processing, the data in this safety data sheet are not necessarily valid for the new-made material. It is the responsibility of the recipient of the product to observe federal, state and local law. Please contact us to obtain up-to-date safety data sheets. This document was issued electronically and has no signature.

Safety Data Sheet according to Regulation (EC) No. 1907/2006 (REACH)

## Tectyl™ 506-EH

Version number: GHS 1.0

Date of compilation: 2024-05-27

### SECTION 1: Identification of the substance/mixture and of the company/undertaking

#### 1.1 Product identifier

Trade name	<b>Tectyl™ 506-EH</b>
Registration number (REACH)	not relevant (mixture)
Unique formula identifier (UFI)	HW24-PCW0-9006-ET30

Article number	TE24827
----------------	---------

#### 1.2 Relevant identified uses of the substance or mixture and uses advised against

Relevant identified uses	Corrosion inhibitor
Uses advised against	Do not use for products which come into contact with foodstuffs. Do not use for private purposes (household).

#### 1.3 Details of the supplier of the safety data sheet

CorPro GmbH  
Frankfurter Straße 63 - 69  
65760 Eschborn  
Germany

Telephone: 00496173 9373-0  
e-mail: info@corpro.gmbh  
Website: www.corpro.gmbh

#### 1.4 Emergency telephone number

Emergency information service	+32 3575 5555 24 hours emergency information -
-------------------------------	--

### SECTION 2: Hazards identification

#### 2.1 Classification of the substance or mixture

Classification according to Regulation (EC) No 1272/2008 (CLP)

Section	Hazard class	Category	Hazard class and category	Hazard statement
2.6	flammable liquid	3	Flam. Liq. 3	H226
3.8D	specific target organ toxicity - single exposure (narcotic effects, drowsiness)	3	STOT SE 3	H336

For full text of abbreviations: see SECTION 16.

The most important adverse physicochemical, human health and environmental effects  
The product is combustible and can be ignited by potential ignition sources.

#### 2.2 Label elements

Labelling according to Regulation (EC) No 1272/2008 (CLP)

- Signal word warning

- Pictograms

GHS02, GHS07



Safety Data Sheet according to Regulation (EC) No. 1907/2006 (REACH)

**Tectyl™ 506-EH**

Version number: GHS 1.0

Date of compilation: 2024-05-27

**- Hazard statements**

H226 Flammable liquid and vapour.  
 H336 May cause drowsiness or dizziness.

**- Precautionary statements**

P210 Keep away from heat, hot surfaces, sparks, open flames and other ignition sources. No smoking.  
 P235 Keep cool.  
 P261 Avoid breathing mist/vapours.  
 P303+P361+P353 IF ON SKIN (or hair): Take off immediately all contaminated clothing. Rinse skin with water.  
 P304+P340 IF INHALED: Remove person to fresh air and keep comfortable for breathing.  
 P312 Call a POISON CENTRE/doctor if you feel unwell.  
 P403+P233 Store in a well-ventilated place. Keep container tightly closed.

**- Supplemental hazard information**

EUH066 Repeated exposure may cause skin dryness or cracking.

**- Hazardous ingredients for labelling**

Hydrocarbons, C9-C11, n-alkanes, isoalkanes, cyclics, <2% aromatics

**2.3 Other hazards**

Special danger of slipping by leaking/spilling product.

**Results of PBT and vPvB assessment**

Does not contain a PBT-/vPvB-substance at a concentration of  $\geq 0,1\%$ .

**Endocrine disrupting properties**



Does not contain an endocrine disruptor (ED) at a concentration of  $\geq 0,1\%$ .

**SECTION 3: Composition/information on ingredients****3.1 Substances**

Not relevant (mixture)

**3.2 Mixtures**

Description of the mixture

Name of substance	Identifier	Wt%	Classification acc. to GHS	Pictograms
Hydrocarbons, C9-C11, n-alkanes, isoalkanes, cyclics, <2% aromatics	CAS No 64742-48-9  EC No 919-857-5  Index No 649-327-00-6  REACH Reg. No 01-2119463258-33-xxxx	25 – < 50	Flam. Liq. 3 / H226 STOT SE 3 / H336 Asp. Tox. 1 / H304	
Sulfonic acids, petroleum, sodium salts	CAS No 68608-26-4  EC No 271-781-5  REACH Reg. No 01-2119527859-22-xxxx	1 – < 5	Eye Irrit. 2 / H319	

Safety Data Sheet according to Regulation (EC) No. 1907/2006 (REACH)

**Tectyl™ 506-EH**

Version number: GHS 1.0

Date of compilation: 2024-05-27

Name of substance	Identifier	Wt%	Classification acc. to GHS	Pictograms
Distillates (petroleum), solvent-dewaxed heavy paraffinic	CAS No 64742-65-0  EC No 265-169-7  Index No 649-474-00-6  REACH Reg. No 01-2119471299-27- xxxx	1 – < 5	Asp. Tox. 1 / H304	

Name of substance	Specific Conc. Limits	M-Factors	ATE	Exposure route
Distillates (petroleum), solvent-dewaxed heavy paraffinic	-	-	11 mg//4h 2.18 mg//4h	inhalation: vapour inhalation: dust/mist

**Remarks**

For full text of abbreviations: see SECTION 16

**SECTION 4: First aid measures****4.1 Description of first aid measures**

## General notes

Do not leave affected person unattended. Remove victim out of the danger area. Keep affected person warm, still and covered. Take off immediately all contaminated clothing. In all cases of doubt, or when symptoms persist, seek medical advice. In case of unconsciousness place person in the recovery position. Never give anything by mouth.

## Following inhalation

If breathing is irregular or stopped, immediately seek medical assistance and start first aid actions. Provide fresh air.

## Following skin contact

Wash with plenty of soap and water. If skin irritation or rash occurs: Get medical advice/attention.

## Following eye contact

Remove contact lenses, if present and easy to do. Continue rinsing. Irrigate copiously with clean, fresh water for at least 10 minutes, holding the eyelids apart. If eye irritation persists: Get medical advice/attention.

## Following ingestion

Rinse mouth with water (only if the person is conscious). Do NOT induce vomiting. If symptoms persist: Get medical advice/attention.

**4.2 Most important symptoms and effects, both acute and delayed**

Narcotic effects.

**4.3 Indication of any immediate medical attention and special treatment needed**

none

**SECTION 5: Firefighting measures****5.1 Extinguishing media**

## Suitable extinguishing media

Alcohol resistant foam, BC-powder, Carbon dioxide (CO<sub>2</sub>), Dry sand

## Unsuitable extinguishing media

Water jet



Safety Data Sheet according to Regulation (EC) No. 1907/2006 (REACH)

**Tectyl™ 506-EH**

Version number: GHS 1.0

Date of compilation: 2024-05-27

**5.2 Special hazards arising from the substance or mixture**

In case of insufficient ventilation and/or in use, may form flammable/explosive vapour-air mixture. Solvent vapours are heavier than air and may spread along floors. Places which are not ventilated, e.g. unventilated below ground level areas such as trenches, conduits and shafts, are particularly prone to the presence of flammable substances or mixtures.

Hazardous combustion products

Carbon monoxide (CO), Carbon dioxide (CO<sub>2</sub>)

**5.3 Advice for firefighters**

In case of fire and/or explosion do not breathe fumes. Co-ordinate firefighting measures to the fire surroundings. Do not allow firefighting water to enter drains or water courses. Collect contaminated firefighting water separately. Fight fire with normal precautions from a reasonable distance.

Special protective equipment for firefighters

Wear self-contained breathing apparatus

**SECTION 6: Accidental release measures****6.1 Personal precautions, protective equipment and emergency procedures**

For non-emergency personnel

Remove persons to safety. Wearing of suitable protective equipment (including personal protective equipment referred to under Section 8 of the safety data sheet) to prevent any contamination of skin, eyes and personal clothing.

For emergency responders

Wear breathing apparatus if exposed to vapours/dust/spray/gases.

**6.2 Environmental precautions**

Keep away from drains, surface and ground water. Retain contaminated washing water and dispose of it.

**6.3 Methods and material for containment and cleaning up**

Advice on how to contain a spill

Covering of drains

Advice on how to clean up a spill

Wipe up with absorbent material (e.g. cloth, fleece). Collect spillage: sawdust, kieselgur (diatomite), sand, universal binder

Appropriate containment techniques

Use of adsorbent materials.

Other information relating to spills and releases

Place in appropriate containers for disposal. Ventilate affected area.

**6.4 Reference to other sections**

Hazardous combustion products: see section 5. Personal protective equipment: see section 8. Incompatible materials: see section 10. Disposal considerations: see section 13.

**SECTION 7: Handling and storage****7.1 Precautions for safe handling**

Recommendations

- Measures to prevent fire as well as aerosol and dust generation

Use local and general ventilation. Avoidance of ignition sources. Keep away from sources of ignition - No smoking. Take precautionary measures against static discharge. Use only in well-ventilated areas. Due to danger of explosion, prevent leakage of vapours into cellars, flues and ditches. Ground/bond container and receiving equipment. Use explosion-proof electrical/ventilating/lighting/equipment. Use only non-sparking tools.



Safety Data Sheet according to Regulation (EC) No. 1907/2006 (REACH)

**Tectyl™ 506-EH**

Version number: GHS 1.0

Date of compilation: 2024-05-27

**- Specific notes/details**

Places which are not ventilated, e.g. unventilated below ground level areas such as trenches, conduits and shafts, are particularly prone to the presence of flammable substances or mixtures. Vapours are heavier than air, spread along floors and form explosive mixtures with air. Vapours may form explosive mixtures with air.

**Advice on general occupational hygiene**

Wash hands after use. Do not eat, drink and smoke in work areas. Remove contaminated clothing and protective equipment before entering eating areas. Never keep food or drink in the vicinity of chemicals. Never place chemicals in containers that are normally used for food or drink. Keep away from food, drink and animal feedingstuffs.

**7.2 Conditions for safe storage, including any incompatibilities****Managing of associated risks****- Explosive atmospheres**

Keep container tightly closed and in a well-ventilated place. Use local and general ventilation. Keep cool. Protect from sunlight.

**- Flammability hazards**

Keep away from sources of ignition - No smoking. Keep away from heat, hot surfaces, sparks, open flames and other ignition sources. No smoking. Take precautionary measures against static discharge. Do not spray on an open flame or other ignition source. Protect from sunlight.

**- Ventilation requirements**

Use local and general ventilation. Ground/bond container and receiving equipment.

**- Packaging compatibilities**

Only packagings which are approved (e.g. acc. to ADR) may be used.

**7.3 Specific end use(s)**

See section 16 for a general overview.

**SECTION 8: Exposure controls/personal protection****8.1 Control parameters**

Occupational exposure limit values (Workplace Exposure Limits)

this information is not available

Relevant DNELs of components						
Name of substance	CAS No	Endpoint	Threshold level	Protection goal, route of exposure	Used in	Exposure time
Sulfonic acids, petroleum, sodium salts	68608-26-4	DNEL	0.66 mg/m <sup>3</sup>	human, inhalatory	worker (industry)	chronic - systemic effects
Sulfonic acids, petroleum, sodium salts	68608-26-4	DNEL	3.33 mg/kg bw/day	human, dermal	worker (industry)	chronic - systemic effects

Relevant PNECs of components						
Name of substance	CAS No	Endpoint	Threshold level	Organism	Environmental compartment	Exposure time
Sulfonic acids, petroleum, sodium salts	68608-26-4	PNEC	1 mg/l	aquatic organisms	freshwater	short-term (single instance)
Sulfonic acids, petroleum, sodium salts	68608-26-4	PNEC	1 mg/l	aquatic organisms	marine water	short-term (single instance)
Sulfonic acids, petroleum, sodium salts	68608-26-4	PNEC	100 mg/l	aquatic organisms	sewage treatment plant (STP)	short-term (single instance)



Safety Data Sheet according to Regulation (EC) No. 1907/2006 (REACH)

**Tectyl™ 506-EH**

Version number: GHS 1.0

Date of compilation: 2024-05-27

Relevant PNECs of components						
Name of substance	CAS No	Endpoint	Threshold level	Organism	Environmental compartment	Exposure time
Sulfonic acids, petroleum, sodium salts	68608-26-4	PNEC	723,500,000 mg/kg	aquatic organisms	freshwater sediment	short-term (single instance)
Sulfonic acids, petroleum, sodium salts	68608-26-4	PNEC	723,500,000 mg/kg	aquatic organisms	marine sediment	short-term (single instance)
Sulfonic acids, petroleum, sodium salts	68608-26-4	PNEC	868,700,000 mg/kg	terrestrial organisms	soil	short-term (single instance)

**8.2 Exposure controls**

## Appropriate engineering controls

General ventilation.

## Individual protection measures (personal protective equipment)

## Eye/face protection

Wear eye/face protection.

## Skin protection

## - Hand protection

Wear suitable gloves. Chemical protection gloves are suitable, which are tested according to EN 374. Check leak-tightness/impermeability prior to use. In the case of wanting to use the gloves again, clean them before taking off and air them well. For special purposes, it is recommended to check the resistance to chemicals of the protective gloves mentioned above together with the supplier of these gloves.

## - Type of material

CR: chloroprene (chlorobutadiene) rubber

## - Other protection measures

Take recovery periods for skin regeneration. Preventive skin protection (barrier creams/ointments) is recommended. Wash hands thoroughly after handling.

## Respiratory protection

In case of inadequate ventilation wear respiratory protection.

## Environmental exposure controls

Use appropriate container to avoid environmental contamination. Keep away from drains, surface and ground water.

**SECTION 9: Physical and chemical properties****9.1 Information on basic physical and chemical properties**

Physical state	liquid (viscous)
Colour	brown
Odour	characteristic
Melting point/freezing point	not determined
Boiling point or initial boiling point and boiling range	not determined
Flammability	flammable liquid in accordance with GHS criteria
Lower and upper explosion limit	not determined
Flash point	40 °C



Safety Data Sheet according to Regulation (EC) No. 1907/2006 (REACH)

**Tectyl™ 506-EH**

Version number: GHS 1.0

Date of compilation: 2024-05-27

Auto-ignition temperature	>200 °C (auto-ignition temperature (liquids and gases))
Decomposition temperature	not relevant
pH (value)	not determined
Kinematic viscosity	>21 mm <sup>2</sup> /s at 40 °C
Dynamic viscosity	3,750 mPa s at 20 °C

## Solubility(ies)

Water solubility	insoluble in water
------------------	--------------------

## Partition coefficient

Partition coefficient n-octanol/water (log value)	this information is not available
---	-----------------------------------

Vapour pressure	not determined
-----------------	----------------

## Density and/or relative density

Density	0.87 g/cm <sup>3</sup>
Relative vapour density	information on this property is not available

Particle characteristics	not relevant (liquid)
--------------------------	-----------------------

**9.2 Other information**

Information with regard to physical hazard classes	there is no additional information
--	------------------------------------

## Other safety characteristics

Temperature class (EU, acc. to ATEX)	T3 (maximum permissible surface temperature on the equipment: 200°C)
--------------------------------------	--

**SECTION 10: Stability and reactivity****10.1 Reactivity**

Concerning incompatibility: see below "Conditions to avoid" and "Incompatible materials". The mixture contains reactive substance(s). Risk of ignition.

If heated:

Risk of ignition

**10.2 Chemical stability**

See below "Conditions to avoid".

**10.3 Possibility of hazardous reactions**

No known hazardous reactions.

**10.4 Conditions to avoid**

Keep away from heat, hot surfaces, sparks, open flames and other ignition sources. No smoking.

Hints to prevent fire or explosion

Use explosion-proof electrical/ventilating/lighting/equipment. Use only non-sparking tools. Take precautionary measures against static discharge.



Safety Data Sheet according to Regulation (EC) No. 1907/2006 (REACH)

**Tectyl™ 506-EH**

Version number: GHS 1.0

Date of compilation: 2024-05-27

**10.5 Incompatible materials**

Oxidisers

**10.6 Hazardous decomposition products**

Reasonably anticipated hazardous decomposition products produced as a result of use, storage, spill and heating are not known. Hazardous combustion products: see section 5.

**SECTION 11: Toxicological information****11.1 Information on hazard classes as defined in Regulation (EC) No 1272/2008**

Test data are not available for the complete mixture.

## Classification procedure

The method for classification of the mixture is based on ingredients of the mixture (additivity formula).

**Classification according to GHS (1272/2008/EC, CLP)**

## Acute toxicity

Shall not be classified as acutely toxic.

Acute toxicity estimate (ATE) of components			
Name of substance	CAS No	Exposure route	ATE
Distillates (petroleum), solvent-dewaxed heavy paraffinic	64742-65-0	inhalation: vapour	11 mg/l/4h
Distillates (petroleum), solvent-dewaxed heavy paraffinic	64742-65-0	inhalation: dust/mist	2.18 mg/l/4h

Acute toxicity of components					
Name of substance	CAS No	Exposure route	Endpoint	Value	Species
Hydrocarbons, C9-C11, n-alkanes, isoalkanes, cyclics, <2% aromatics	64742-48-9	oral	LD50	>5,000 mg/kg	rat
Hydrocarbons, C9-C11, n-alkanes, isoalkanes, cyclics, <2% aromatics	64742-48-9	inhalation: vapour	LC50	>9,300 mg/m <sup>3</sup> /4h	rat
Hydrocarbons, C9-C11, n-alkanes, isoalkanes, cyclics, <2% aromatics	64742-48-9	dermal	LD50	>2,000 mg/kg	rat
Sulfonic acids, petroleum, sodium salts	68608-26-4	inhalation: dust/mist	LC50	>1.9 mg/l/4h	rat
Sulfonic acids, petroleum, sodium salts	68608-26-4	dermal	LD50	>5,000 mg/kg	rabbit
Distillates (petroleum), solvent-dewaxed heavy paraffinic	64742-65-0	oral	LD50	>5,000 mg/kg	rat
Distillates (petroleum), solvent-dewaxed heavy paraffinic	64742-65-0	inhalation: dust/mist	LC50	2.18 mg/l/4h	rat
Distillates (petroleum), solvent-dewaxed heavy paraffinic	64742-65-0	dermal	LD50	>5,000 mg/kg	rabbit

## Skin corrosion/irritation

Shall not be classified as corrosive/irritant to skin.

## Serious eye damage/eye irritation

Shall not be classified as seriously damaging to the eye or eye irritant.

## Respiratory or skin sensitisation

Shall not be classified as a respiratory or skin sensitiser.



Safety Data Sheet according to Regulation (EC) No. 1907/2006 (REACH)

**Tectyl™ 506-EH**

Version number: GHS 1.0

Date of compilation: 2024-05-27

**Germ cell mutagenicity**

Shall not be classified as germ cell mutagenic.

**Carcinogenicity**

Shall not be classified as carcinogenic.

**Reproductive toxicity**

Shall not be classified as a reproductive toxicant.

**Specific target organ toxicity - single exposure**

May cause drowsiness or dizziness.

**Specific target organ toxicity - repeated exposure**

Shall not be classified as a specific target organ toxicant (repeated exposure).

**Aspiration hazard**

Shall not be classified as presenting an aspiration hazard.

**Other information**

Repeated exposure may cause skin dryness or cracking.

**11.2 Information on other hazards**

There is no additional information.

**SECTION 12: Ecological information****12.1 Toxicity**

Shall not be classified as hazardous to the aquatic environment.

Aquatic toxicity (acute) of components					
Name of substance	CAS No	Endpoint	Value	Species	Exposure time
Hydrocarbons, C9-C11, n-alkanes, isoalkanes, cyclics, <2% aromatics	64742-48-9	LL50	>1,000 mg/l	fish	24 h
Hydrocarbons, C9-C11, n-alkanes, isoalkanes, cyclics, <2% aromatics	64742-48-9	EL50	>1,000 mg/l	aquatic invertebrates	24 h
Hydrocarbons, C9-C11, n-alkanes, isoalkanes, cyclics, <2% aromatics	64742-48-9	LC50	>0.004 mg/l	aquatic invertebrates	96 h
Hydrocarbons, C9-C11, n-alkanes, isoalkanes, cyclics, <2% aromatics	64742-48-9	EC50	>0.004 mg/l	aquatic invertebrates	48 h
Sulfonic acids, petroleum, sodium salts	68608-26-4	LL50	>10,000 mg/l	fish	96 h
Sulfonic acids, petroleum, sodium salts	68608-26-4	EC50	>1,000 mg/l	aquatic invertebrates	48 h
Sulfonic acids, petroleum, sodium salts	68608-26-4	ErC50	>1,000 mg/l	algae	72 h
Distillates (petroleum), solvent-dewaxed heavy paraffinic	64742-65-0	LL50	>100 mg/l	fish	96 h

Safety Data Sheet according to Regulation (EC) No. 1907/2006 (REACH)

**Tectyl™ 506-EH**

Version number: GHS 1.0

Date of compilation: 2024-05-27

Aquatic toxicity (acute) of components					
Name of substance	CAS No	Endpoint	Value	Species	Exposure time
Distillates (petroleum), solvent-dewaxed heavy paraffinic	64742-65-0	EL50	>10,000 mg/l	aquatic invertebrates	24 h

Aquatic toxicity (chronic) of components					
Name of substance	CAS No	Endpoint	Value	Species	Exposure time
Hydrocarbons, C9-C11, n-alkanes, isoalkanes, cyclics, <2% aromatics	64742-48-9	LL50	>100 mg/l	fish	3 h
Sulfonic acids, petroleum, sodium salts	68608-26-4	EC50	≤5,000 mg/l	microorganisms	8 h

**12.2 Persistence and degradability**

Degradability of components						
Name of substance	CAS No	Process	Degradation rate	Time	Method	Source
Hydrocarbons, C9-C11, n-alkanes, isoalkanes, cyclics, <2% aromatics	64742-48-9	oxygen depletion	10 %	5 d		ECHA
Hydrocarbons, C9-C11, n-alkanes, isoalkanes, cyclics, <2% aromatics	64742-48-9	carbon dioxide generation	78 %	28 d		ECHA

**12.3 Bioaccumulative potential**

Data are not available.

Bioaccumulative potential of components				
Name of substance	CAS No	BCF	Log KOW	BOD5/COD
Hydrocarbons, C9-C11, n-alkanes, isoalkanes, cyclics, <2% aromatics	64742-48-9	≥30.85 – ≤2,626	≥3.17 – ≤6.23 (pH value: ~7, 20 °C)	

**12.4 Mobility in soil**

Data are not available.

**12.5 Results of PBT and vPvB assessment**

According to the results of its assessment, this substance is not a PBT or a vPvB. Does not contain a PBT-/vPvB-substance at a concentration of ≥ 0,1%.

**12.6 Endocrine disrupting properties**

Does not contain an endocrine disruptor (ED) at a concentration of ≥ 0,1%.

**12.7 Other adverse effects**

Data are not available.



Safety Data Sheet according to Regulation (EC) No. 1907/2006 (REACH)

**Tectyl™ 506-EH**

Version number: GHS 1.0

Date of compilation: 2024-05-27

**SECTION 13: Disposal considerations****13.1 Waste treatment methods**

Waste treatment-relevant information

Solvent reclamation/regeneration.

Sewage disposal-relevant information

Do not empty into drains. Avoid release to the environment. Refer to special instructions/safety data sheets.

Waste treatment of containers/packagings

It is a dangerous waste; only packagings which are approved (e.g. acc. to ADR) may be used. Completely emptied packages can be recycled. Handle contaminated packages in the same way as the substance itself.

**Remarks**

Please consider the relevant national or regional provisions. Waste shall be separated into the categories that can be handled separately by the local or national waste management facilities.

**SECTION 14: Transport information****14.1 UN number or ID number**

ADR	UN 1139
IMDG-Code	UN 1139
ICAO-TI	UN 1139

**14.2 UN proper shipping name**

ADR	COATING SOLUTION
IMDG-Code	COATING SOLUTION
ICAO-TI	Coating solution

**14.3 Transport hazard class(es)**

ADR	3
IMDG-Code	3
ICAO-TI	3

**14.4 Packing group**

ADR	III
IMDG-Code	III
ICAO-TI	III

**14.5 Environmental hazards**

non-environmentally hazardous acc. to the dangerous goods regulations

**14.6 Special precautions for user**

Provisions for dangerous goods (ADR) should be complied within the premises.

**14.7 Maritime transport in bulk according to IMO instruments**

The cargo is not intended to be carried in bulk.

**Information for each of the UN Model Regulations**



Safety Data Sheet according to Regulation (EC) No. 1907/2006 (REACH)

**Tectyl™ 506-EH**

Version number: GHS 1.0

Date of compilation: 2024-05-27

**Agreement concerning the International Carriage of Dangerous Goods by Road (ADR) - Additional information**

Classification code	F1
Danger label(s)	3

**International Maritime Dangerous Goods Code (IMDG) - Additional information**

Marine pollutant	-
Danger label(s)	3

**International Civil Aviation Organization (ICAO-IATA/DGR) - Additional information**

Danger label(s)	3
-----------------	---

**SECTION 15: Regulatory information****15.1 Safety, health and environmental regulations/legislation specific for the substance or mixture****Relevant provisions of the European Union (EU)****Restrictions according to REACH, Annex XVII**

Dangerous substances with restrictions (REACH, Annex XVII)				
Name of substance	Name acc. to inventory	CAS No	Restriction	No
Tectyl™ 506-EH	this product meets the criteria for classification in accordance with Regulation No 1272/2008/EC		R3	3
Hydrocarbons, C9-C11, n-alkanes, isoalkanes, cyclics, <2% aromatics	flammable / pyrophoric		R40	40
Sulfonic acids, petroleum, sodium salts	substances in tattoo inks and permanent make-up		R75	75

**Legend**

R3 1. Shall not be used in:  
- ornamental articles intended to produce light or colour effects by means of different phases, for example in ornamental



Safety Data Sheet according to Regulation (EC) No. 1907/2006 (REACH)

**Tectyl™ 506-EH**

Version number: GHS 1.0

Date of compilation: 2024-05-27

Legend

- lamps and ashtrays,  
- tricks and jokes,  
- games for one or more participants, or any article intended to be used as such, even with ornamental aspects,  
2. Articles not complying with paragraph 1 shall not be placed on the market.  
3. Shall not be placed on the market if they contain a colouring agent, unless required for fiscal reasons, or perfume, or both, if they:  
— can be used as fuel in decorative oil lamps for supply to the general public, and  
— present an aspiration hazard and are labelled with H304.  
4. Decorative oil lamps for supply to the general public shall not be placed on the market unless they conform to the European Standard on Decorative oil lamps (EN 14059) adopted by the European Committee for Standardisation (CEN).  
5. Without prejudice to the implementation of other Union provisions relating to the classification, labelling and packaging of substances and mixtures, suppliers shall ensure, before the placing on the market, that the following requirements are met:  
(a) lamp oils, labelled with H304, intended for supply to the general public are visibly, legibly and indelibly marked as follows: "Keep lamps filled with this liquid out of the reach of children"; and, by 1 December 2010, "Just a sip of lamp oil – or even sucking the wick of lamps – may lead to life-threatening lung damage";  
(b) grill lighter fluids, labelled with H304, intended for supply to the general public are legibly and indelibly marked by 1 December 2010 as follows: "Just a sip of grill lighter fluid may lead to life threatening lung damage";  
(c) lamps oils and grill lighters, labelled with H304, intended for supply to the general public are packaged in black opaque containers not exceeding 1 litre by 1 December 2010.;
- R40
1. Shall not be used, as substance or as mixtures in aerosol dispensers where these aerosol dispensers are intended for supply to the general public for entertainment and decorative purposes such as the following:
    - metallic glitter intended mainly for decoration,
    - artificial snow and frost,
    - 'whoopee' cushions,
    - silly string aerosols,
    - imitation excrement,
    - horns for parties,
    - decorative flakes and foams,
    - artificial cobwebs,
    - stink bombs.
  2. Without prejudice to the application of other Community provisions on the classification, packaging and labelling of substances, suppliers shall ensure before the placing on the market that the packaging of aerosol dispensers referred to above is marked visibly, legibly and indelibly with:  
'For professional users only'.
  3. By way of derogation, paragraphs 1 and 2 shall not apply to the aerosol dispensers referred to Article 8 (1a) of Council Directive 75/324/EEC (2).
  4. The aerosol dispensers referred to in paragraphs 1 and 2 shall not be placed on the market unless they conform to the requirements indicated.



Safety Data Sheet according to Regulation (EC) No. 1907/2006 (REACH)

**Tectyl™ 506-EH**

Version number: GHS 1.0

Date of compilation: 2024-05-27

Legend

R75

1. Shall not be placed on the market in mixtures for use for tattooing purposes, and mixtures containing any such substances shall not be used for tattooing purposes, after 4 January 2022 if the substance or substances in question is or are present in the following circumstances:
- (a) in the case of a substance classified in Part 3 of Annex VI to Regulation (EC) No 1272/2008 as carcinogen category 1A, 1B or 2, or germ cell mutagen category 1A, 1B or 2, the substance is present in the mixture in a concentration equal to or greater than 0,00005 % by weight;
  - (b) in the case of a substance classified in Part 3 of Annex VI to Regulation (EC) No 1272/2008 as reproductive toxicant category 1A, 1B or 2, the substance is present in the mixture in a concentration equal to or greater than 0,001 % by weight;
  - (c) in the case of a substance classified in Part 3 of Annex VI to Regulation (EC) No 1272/2008 as skin sensitiser category 1, 1A or 1B, the substance is present in the mixture in a concentration equal to or greater than 0,001 % by weight;
  - (d) in the case of a substance classified in Part 3 of Annex VI to Regulation (EC) No 1272/2008 as skin corrosive category 1, 1A, 1B or 1C or skin irritant category 2, or as serious eye damage category 1 or eye irritant category 2, the substance is present in the mixture in a concentration equal to or greater than:
    - (i) 0,1 % by weight, if the substance is used solely as a pH regulator;
    - (ii) 0,01 % by weight, in all other cases;
  - (e) in the case of a substance listed in Annex II to Regulation (EC) No 1223/2009 (\*1), the substance is present in the mixture in a concentration equal to or greater than 0,00005 % by weight;
  - (f) in the case of a substance for which a condition of one or more of the following kinds is specified in column g (Product type, Body parts) of the table in Annex IV to Regulation (EC) No 1223/2009, the substance is present in the mixture in a concentration equal to or greater than 0,00005 % by weight:
    - (i) "Rinse-off products";
    - (ii) "Not to be used in products applied on mucous membranes";
    - (iii) "Not to be used in eye products";
  - (g) in the case of a substance for which a condition is specified in column h (Maximum concentration in ready for use preparation) or column i (Other) of the table in Annex IV to Regulation (EC) No 1223/2009, the substance is present in the mixture in a concentration, or in some other way, that does not accord with the condition specified in that column;
  - (h) in the case of a substance listed in Appendix 13 to this Annex, the substance is present in the mixture in a concentration equal to or greater than the concentration limit specified for that substance in that Appendix.
2. For the purposes of this entry use of a mixture "for tattooing purposes" means injection or introduction of the mixture into a person's skin, mucous membrane or eyeball, by any process or procedure (including procedures commonly referred to as permanent make-up, cosmetic tattooing, micro-blading and micro-pigmentation), with the aim of making a mark or design on his or her body.
3. If a substance not listed in Appendix 13 falls within more than one of points (a) to (g) of paragraph 1, the strictest concentration limit laid down in the points in question shall apply to that substance. If a substance listed in Appendix 13 also falls within one or more of points (a) to (g) of paragraph 1, the concentration limit laid down in point (h) of paragraph 1 shall apply to that substance.
4. By way of derogation, paragraph 1 shall not apply to the following substances until 4 January 2023:
- (a) Pigment Blue 15:3 (CI 74160, EC No 205-685-1, CAS No 147-14-8);
  - (b) Pigment Green 7 (CI 74260, EC No 215-524-7, CAS No 1328-53-6).
5. If Part 3 of Annex VI to Regulation (EC) No 1272/2008 is amended after 4 January 2021 to classify or re-classify a substance such that the substance then becomes caught by point (a), (b), (c) or (d) of paragraph 1 of this entry, or such that it then falls within a different one of those points from the one within which it fell previously, and the date of application of that new or revised classification is after the date referred to in paragraph 1 or, as the case may be, paragraph 4 of this entry, that amendment shall, for the purposes of applying this entry to that substance, be treated as taking effect on the date of application of that new or revised classification.
6. If Annex II or Annex IV to Regulation (EC) No 1223/2009 is amended after 4 January 2021 to list or change the listing of a substance such that the substance then becomes caught by point (e), (f) or (g) of paragraph 1 of this entry, or such that it then falls within a different one of those points from the one within which it fell previously, and the amendment takes effect after the date referred to in paragraph 1 or, as the case may be, paragraph 4 of this entry, that amendment shall, for the purposes of applying this entry to that substance, be treated as taking effect from the date falling 18 months after entry into force of the act by which that amendment was made.
7. Suppliers placing a mixture on the market for use for tattooing purposes shall ensure that, after 4 January 2022, the mixture is marked with the following information:
- (a) the statement "Mixture for use in tattoos or permanent make-up";
  - (b) a reference number to uniquely identify the batch;
  - (c) the list of ingredients in accordance with the nomenclature established in the glossary of common ingredient names pursuant to Article 33 of Regulation (EC) No 1223/2009, or in the absence of a common ingredient name, the IUPAC name. In the absence of a common ingredient name or IUPAC name, the CAS and EC number. Ingredients shall be listed in descending order by weight or volume of the ingredients at the time of formulation. "Ingredient" means any substance added during the process of formulation and present in the mixture for use for tattooing purposes. Impurities shall not be regarded as ingredients. If the name of a substance, used as ingredient within the meaning of this entry, is already required to be stated on the label in accordance with Regulation (EC) No 1272/2008, that ingredient does not need to be marked in accordance with this Regulation;
  - (d) the additional statement "pH regulator" for substances falling under point (d)(i) of paragraph 1;
  - (e) the statement "Contains nickel. Can cause allergic reactions." if the mixture contains nickel below the concentration limit specified in Appendix 13;
  - (f) the statement "Contains chromium (VI). Can cause allergic reactions." if the mixture contains chromium (VI) below the concentration limit specified in Appendix 13;
  - (g) safety instructions for use insofar as they are not already required to be stated on the label by Regulation (EC) No 1272/2008.
- The information shall be clearly visible, easily legible and marked in a way that is indelible.
- The information shall be written in the official language(s) of the Member State(s) where the mixture is placed on the market, unless the Member State(s) concerned provide(s) otherwise.
- Where necessary because of the size of the package, the information listed in the first subparagraph, except for point (a), shall be included instead in the instructions for use.
- Before using a mixture for tattooing purposes, the person using the mixture shall provide the person undergoing the procedure with the information marked on the package or included in the instructions for use pursuant to this paragraph.
8. Mixtures that do not contain the statement "Mixture for use in tattoos or permanent make-up" shall not be used for tattooing purposes.



Safety Data Sheet according to Regulation (EC) No. 1907/2006 (REACH)

**Tectyl™ 506-EH**

Version number: GHS 1.0

Date of compilation: 2024-05-27

Legend

9. This entry does not apply to substances that are gases at temperature of 20 °C and pressure of 101,3 kPa, or generate a vapour pressure of more than 300 kPa at temperature of 50 °C, with the exception of formaldehyde (CAS No 50-00-0, EC No 200-001-8).

10. This entry does not apply to the placing on the market of a mixture for use for tattooing purposes, or to the use of a mixture for tattooing purposes, when placed on the market exclusively as a medical device or an accessory to a medical device, within the meaning of Regulation (EU) 2017/745, or when used exclusively as a medical device or an accessory to a medical device, within the same meaning. Where the placing on the market or use may not be exclusively as a medical device or an accessory to a medical device, the requirements of Regulation (EU) 2017/745 and of this Regulation shall apply cumulatively.

**List of substances subject to authorisation (REACH, Annex XIV) / SVHC - candidate list**

none of the ingredients are listed

**Deco-Paint Directive**

VOC content	<60 %
-------------	-------

**Industrial Emissions Directive (IED)**

VOC content	<55 %
-------------	-------

**Directive on the restriction of the use of certain hazardous substances in electrical and electronic equipment (RoHS)**

none of the ingredients are listed

**Regulation concerning the establishment of a European Pollutant Release and Transfer Register (PRTR)**

none of the ingredients are listed

**Water Framework Directive (WFD)**

List of pollutants (WFD)			
Name of substance	CAS No	Listed in	Remarks
Distillates (petroleum), solvent-dewaxed heavy paraffinic		a)	

Legend

a) Indicative list of the main pollutants

**Regulation on persistent organic pollutants (POP)**

none of the ingredients are listed

**National inventories**

Country	Inventory	Status
EU	REACH Reg.	all ingredients are listed
US	TSCA	all ingredients are listed (ACTIVE)

Legend

REACH Reg. REACH registered substances

TSCA Toxic Substance Control Act

**15.2 Chemical safety assessment**

Chemical safety assessments for substances in this mixture were not carried out.



Safety Data Sheet according to Regulation (EC) No. 1907/2006 (REACH)

**Tectyl™ 506-EH**

Version number: GHS 1.0

Date of compilation: 2024-05-27

**SECTION 16: Other information****Abbreviations and acronyms**

<b>Abbr.</b>	<b>Descriptions of used abbreviations</b>
ADR	Accord relatif au transport international des marchandises dangereuses par route (Agreement concerning the International Carriage of Dangerous Goods by Road)
Asp. Tox.	Aspiration hazard
ATE	Acute Toxicity Estimate
BCF	Bioconcentration factor
BOD	Biochemical Oxygen Demand
CAS	Chemical Abstracts Service (service that maintains the most comprehensive list of chemical substances)
CLP	Regulation (EC) No 1272/2008 on classification, labelling and packaging of substances and mixtures
COD	Chemical oxygen demand
DGR	Dangerous Goods Regulations (see IATA/DGR)
DNEL	Derived No-Effect Level
EC50	Effective Concentration 50 %. The EC50 corresponds to the concentration of a tested substance causing 50 % changes in response (e.g. on growth) during a specified time interval
EC No	The EC Inventory (EINECS, ELINCS and the NLP-list) is the source for the seven-digit EC number, an identifier of substances commercially available within the EU (European Union)
ED	Endocrine disruptor
EINECS	European Inventory of Existing Commercial Chemical Substances
EL50	Effective Loading 50 %: the EL50 corresponds to the loading rate required to produce a response in 50% of the test organisms
ELINCS	European List of Notified Chemical Substances
EmS	Emergency Schedule
ErC50	≡ EC50: in this method, that concentration of test substance which results in a 50 % reduction in either growth (EbC50) or growth rate (ErC50) relative to the control
Eye Dam.	Seriously damaging to the eye
Eye Irrit.	Irritant to the eye
Flam. Liq.	Flammable liquid
GHS	"Globally Harmonized System of Classification and Labelling of Chemicals" developed by the United Nations
IATA	International Air Transport Association
IATA/DGR	Dangerous Goods Regulations (DGR) for the air transport (IATA)
ICAO	International Civil Aviation Organization
ICAO-TI	Technical instructions for the safe transport of dangerous goods by air
IMDG	International Maritime Dangerous Goods Code
IMDG-Code	International Maritime Dangerous Goods Code
index No	The Index number is the identification code given to the substance in Part 3 of Annex VI to Regulation (EC) No 1272/2008
LC50	Lethal Concentration 50%: the LC50 corresponds to the concentration of a tested substance causing 50 % lethality during a specified time interval



Safety Data Sheet according to Regulation (EC) No. 1907/2006 (REACH)

**Tectyl™ 506-EH**

Version number: GHS 1.0

Date of compilation: 2024-05-27

Abbr.	Descriptions of used abbreviations
LD50	Lethal Dose 50 %: the LD50 corresponds to the dose of a tested substance causing 50 % lethality during a specified time interval
LL50	Lethal Loading 50 %: the LL50 corresponds to the loading rate causing 50 % lethality
log KOW	n-Octanol/water
NLP	No-Longer Polymer
PBT	Persistent, Bioaccumulative and Toxic
PNEC	Predicted No-Effect Concentration
REACH	Registration, Evaluation, Authorisation and Restriction of Chemicals
STOT SE	Specific target organ toxicity - single exposure
SVHC	Substance of Very High Concern
VOC	Volatile Organic Compounds
vPvB	Very Persistent and very Bioaccumulative

**Key literature references and sources for data**

Regulation (EC) No 1272/2008 on classification, labelling and packaging of substances and mixtures. Regulation (EC) No. 1907/2006 (REACH), amended by 2020/878/EU.

Agreement concerning the International Carriage of Dangerous Goods by Road (ADR). International Maritime Dangerous Goods Code (IMDG). Dangerous Goods Regulations (DGR) for the air transport (IATA).

**Classification procedure**

Physical and chemical properties: The classification is based on tested mixture.

Health hazards, Environmental hazards: The method for classification of the mixture is based on ingredients of the mixture (additivity formula).

**List of relevant phrases (code and full text as stated in section 2 and 3)**

Code	Text
H226	Flammable liquid and vapour.
H304	May be fatal if swallowed and enters airways.
H319	Causes serious eye irritation.
H336	May cause drowsiness or dizziness.

**Disclaimer**

This information is based upon the present state of our knowledge. This SDS has been compiled and is solely intended for this product.