

MILITARY VEHICLES ENGINES

INTRODUCING THE RENK AMERICA AVDS-1790-2CAU.

- / Direct replacement M60 repower with no change to hull or powerpack integration
- / Base 750 hp readily upgradeable to 1050 hp with latest design improvements
- / Technology upgrades and current production supports long term sustainability
- / US based technology is readily exportable

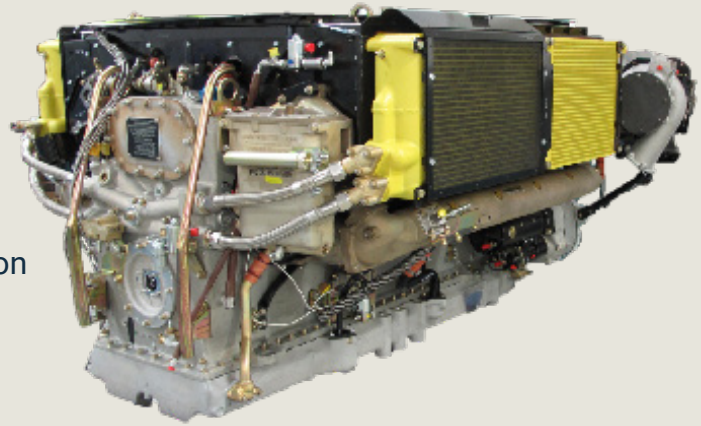

Flexible performance & sustainable drop in solution

Multiple power configurations with the same base engine



750 hp Improved durability & sustainability



950 hp Improved mobility or same performance at higher weight



1050 hp Improved mobility at higher vehicle weight

Direct, trouble-free replacement

Product improved version of the standard M60 engine, with the same form, fit and function as the original.

Product benefits

- New engine configuration, fully supported by the Original Equipment Manufacturer, (OEM) & design authority - RENK America of Muskegon, Michigan - USA
- Engine changes & incorporated improvements are the result of better materials, improved engineering designs, customer requirements/requests & advances in technology
- For long-term sustainability & obsolescence avoidance, this design & most components are derived from the -8 series engine, which is in current production for front line, combat vehicles
- Readily upgradeable to 1,050hp as the engine power components are fully developed & validated with thousands of units fielded at this power rating

INTRODUCING THE RENK AMERICA AVDS-1790-2CAU.

Proven performance & reliability with more than 35,000 AVDS-1790 engines fielded.

RENK America is the Original Equipment Manufacturer (OEM) of the AVDS-1790 Series Engine, standard in M60, M88, M48, & many allied combat vehicles. For decades, more than 35,000 engines have been engineered, manufactured, overhauled and upgraded in Muskegon, Michigan, ensuring the highest quality and reliability to our customers. Our refined manufacturing expertise and continuous technical development of the AVDS-1790 Series Engine ensures RENK America is the only trusted source for your requirements.

Technical data

Powerpack Cooling	Efficient Integrated Air to Air
Square Bore/Stroke mm (in)	146 (5.75)
Displacement, Total L (cu. in)	29.3 (1790)
Number of cylinders	12
Dimensions* (L x W x H) mm (in)	1905 (75) x 1778 (70) x 1143 (45)
Mass, Dry Kg (lbs)	2313 (5100)
Generator	600 & 800 AMP Options

* Dimensions shown are approximate. Engine layout can be adapted to the application of interest.

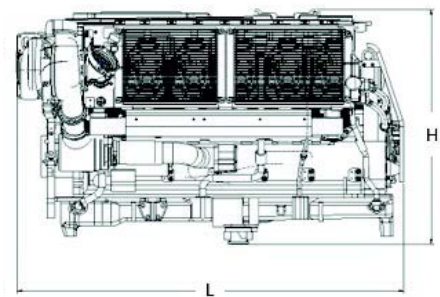
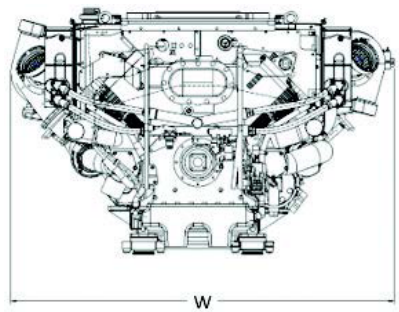

Torque

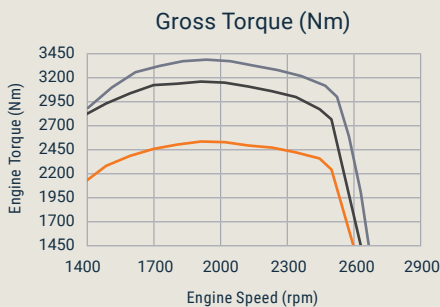

— 783 KW (8DR) — 588 KW (2CAU) — 708 KW (5AR)

Power

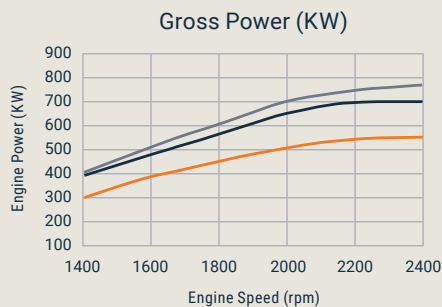

Fuel consumption

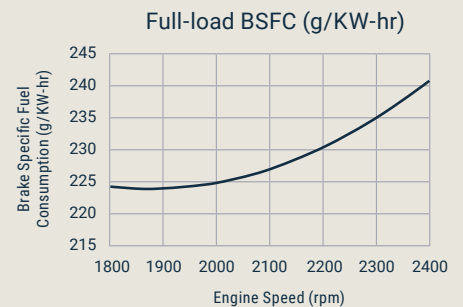

Trusted Partner.

RENK America

76 S. Getty Street
Muskegon, MI 49442, USA
P +1 231 329-6474
E corey.johnson2@renk-america.com
www.renk-america.com

Data, including specifications, contained within this document are summary in nature and subject to change at any time without notice of RENK Americas' discretion. Call for latest revision. All brand names and product names referenced are trademarks, registered trademarks, or trade names of their respective holders. This document consists of general capabilities information that is not defined as controlled technical data under ITAR Part 120.10 or EAR Part 772. © 2023 RENK America

More information

www.renk-group.com/goto/r-0386bf9

